



adt-audio

User Manual

**TOOLMIX
TOOLMST**

Version d/2011 • English

analoge + digitale Tonstudioteknik Karl Jüngling • Inh. Dipl.-Ing. Gerd Jüngling

4 - 6, Scholtwiese • Gladbeck, D45966 • NRW, Germany • Phone: 0(049) 2043 51061 • Fax: 0(049) 2043 56844
E-Mail: info@adt-audio.com • Web: www.adt-audio.com www.adt-audio.de www.pro-audio-store.de



Table of Contents

Before you begin.....3	ToolMix16 Block Diagram.....26
Safety Hints.....3	ToolMix16 technical Data.....27
The ToolMix System....4	ToolMix32 Description.....28
The Units, ToolMix8, Toolmix16, Toolmix32....5	ToolMix32 Block Diagram.....29
ToolMst, Power Supply Units, Cables....6	ToolMix32 technical Data....30
Connector Types.....7	ToolMst Overview, Block Diagrams, Daten....31
Power Supply Connection....8	ToolMst Master Section....32
Mains Power Hints....9	ToolMst PFL, Control Room Section....33
Coupling of Tool Modules....10	ToolMst Playback Section....34
The Master Switch....12	ToolMst Talkback, Block Diagram....35
Grounding....13	ToolMst, technical Data....36
ToolMix8 Connectors....13	Appendix, technical Data, Diagrams....37
ToolMix16 Connectors....14	Power Supply Units ToolPwr-M, ToolPwr-S....38
ToolMix32 Connectors....15	ToolPwr-E, Current Consumption....39
ToolMstConnectors....16	Mains Power Supply, Cables....40
ToolMst Coupling to a ToolMod Console....19	Maintenance, Environmental Conditions....41
ToolMix8 Description....21	
ToolMix8 Block Diagram....23	
ToolMix8 technical Data....24	
ToolMix16 Description....25	

This manual contains information on the adt-audio Toolmix/ToolMst system that has been carefully checked. In line with a policy of continuous development, information may be changed or updated without notice. adt-audio may also make improvements and/or changes in the products described in this information at any time. Technical data and/or the description of functions are always non-binding quotations and no warranted attributes. Product pictures may differ from the current version concerning details and can contain optional equipment that is not part of the standard scope of supply without express hints. We advise users to contact adt-audio for personal attention and up to date information for specific products. Creative involvement from human beings also may mean that information on this Web site may contain technical inaccuracies or typographical errors.



This manual contains information on the installation and operation of the ToolMix8, ToolMix16, and ToolMix32 summing mixers and the ToolMst master and monitor unit in rack-mounted format.

Before you begin:

Please check as soon as you get the devices if the cardboard boxes or wooden crates are damaged in any way.

If even possible, open the boxes as long as the forwarder or parcel service employee is present. If this is not possible, ask her or him for a written confirmation of the damage. All our shipments are insured; however, the insurance will only pay if there is evidence that the damage was caused by the transport.

So please, if you can find any damage follow these rules to avoid any trouble:

- **Get a written confirmation from the forwarder that the delivery was damaged in transit**
- **If you missed to check for damage with the forwarder, look for a witness and make records of time and date, name and address of the witness, and of the facts concerning the damage**
- **Take some pictures of the damage before you open the boxes**
- **If even possible, open the package while the forwarder or a witness is present and check if the devices are also damaged**
- **Inform us as soon as possible**



MOST IMPORTANT SAFETY HINTS:

IF THE DELIVERY CONTAINS DEVICES THAT HAVE TO BE CONNECTED TO THE MAINS POWER LINE, MAKE SURE THAT YOU FOLLOW THE COMMON SAFETY RULES FOR HIGH VOLTAGE ELECTRIC CIRCUITS.

NEVER REMOVE PROTECTION GROUNDS!

MAKE SURE THAT ALL CABLES AND SOCKETS ARE IN PROPER STATE AND THAT THE INSTALLATION IS SAFE!

IF YOU NEED TO OPEN A DEVICE, REMOVE THE MAINS POWER CABLE FROM THE DEVICE BEFORE YOU OPEN THE CASE. SWITCHING OFF THE DEVICES DOES NOT MEAN THAT THE DEVICE IS HARMLESS.

DO NOT MAKE ANY MODIFICATIONS INSIDE THE DEVICES – YOUR LIFE IS IN DANGER!

You will loose your warranty if you make unauthorized modifications of the devices. We are not liable for any damage or injury resulting from unauthorized modifications.

DEVICES MAY HAVE SHARP EDGES THAT MIGHT HURT YOU

MAKE SURE THAT YOU HANDLE WITH CARE WHILE YOU INSTALL THE DEVICES.

READ CAREFULLY AND FOLLOW THE DETAILED SAFETY INSTRUCTIONS ON THE PAGES 6 - 9 OF THIS MANUAL.



Preface and Disclaimer

This manual contains general information on the adt-audio® Tool-Mix system of summing boxes, 1U-high mixers, master modules, and power supply units. By no means does this information represent guaranteed particular characteristics or results of use. The information in this manual has been carefully compiled and verified.

In line with a policy of continuous development, information may be changed or updated without notice. adt-audio® may also make improvements and/or changes in the products described in this information at any time. Technical data and/or the description of functions are always non-binding quotations and no warranted attributes. Product picture may differ from the current version about details and can contain optional equipment, which is not part of the standard scope of supply without express hints. Users are advised to contact adt-audio® for personal attention and up to date information for specific products. Creative involvement from human beings also may mean that information on this Web site may contain technical inaccuracies or typographical errors. All specifications are subject to change without notice.

CE Declaration of Conformity

Manufacturer: Fa. Karl Juengling
Type of Equipment: Audio Signal Processor
Product: ToolMod Pro-Audio Module System,
consisting of:
Modules, Mounting Frames,
Power Supply Units and Accessories
Compliance Engineer: Gerd Juengling



Test Basis:

EN50081-1:1992, EN50082-1:1992, EN61000-3-3:1995,
EN60065:1993 Class1, EN61000-3-2:2000,
EN60065:2002, EN55013:2001, EN55020:2002,
73/23 EWG; 93/68 EWG

We hereby declare that the construction of the ToolMod system complies with the standards and regulations listed above.

Environmental Protection

This product can be recycled. Products bearing this symbol must not be thrown away with normal household waste. At the end of the product's life, take it to a collection Point designated for recycling of electrical and electronic devices. Find out more about return and collection points through your local authorities.



The European Waste Electrical and Electronic Equipment (WEEE) Directive was implemented to dramatically reduce the amount of waste going to landfills, thereby reducing the environmental impact on the planet and on human health. Please act responsibly by recycling used products. If this product is still useable, consider giving it away or selling it.

WEEE-Registration: DE 59049716



Copyright

This manual is copyright protected. Do not copy, distribute, or translate into other languages without permission in writing from adt-audio® Karl Juengling. All rights reserved.

Trade Marks

adt-audio®, ToolMod®, V700®, 5MT®, and Pro-Audio-Store® are registered trademarks of analoge + digitale Tonstudioteknik Karl Juengling.

All other trademarks are the property of their respective owners.

Symbols and Notes

The lightning symbol in a triangle warns about the possibility of dangerous electrical shocks.



This symbol warns about the risk of death by electric shocks.



The exclamation mark inside a triangle makes you aware of important warnings and operational advice.



Important Safety Instructions

- **Please note and retain this information!**
- **Read and follow all safety and operation instructions carefully before you start using the product!**
- **Heed all warnings!**

Extensive information on the entire ToolMix system and manuals for download can be found on our website www.adt-audio.com.

Water and Humidity

Do not use the devices near water, near a bathtub, in a wet basement, near a swimming pool, and the like. Do not expose the devices to rain or moisture.



WARNING:
RISK OF DEATH BY ELECTRIC SHOCK!

Insertion of objects or fluids

NEVER allow any kind of object to get into the devices thru ventilation slots or other openings in the housing. You can easily be exposed to dangerous electric voltage or cause damaging short circuits.

NEVER allow any kind of fluids to be spilled or sprayed on the devices. Such actions can cause damage, dangerous electric shocks, or fire.

WARNING:



RISK OF DEATH BY ELECTRIC SHOCK!

In case an object or fluids got into a device, disconnect the power immediately and contact a qualified service technician!



Power Supply Units

Do not defeat the safety purpose of the grounding type Euro outlet. Use only power cables and wall outlets that provide protective ground connection to the power supply units. Grounding type cables and outlets have two contacts for the ac line and a third grounding contact. The third, grounding contact is provided for your safety. If the provided cable does not fit into your wall socket, consult an electrician for replacement.

Power Cord

Protect the power cord from being walked on or pinched particularly at plugs, convenience receptacles, and the point where they exit from the power supply unit.

Lightning Storms

Unplug the power supply units before lightning storms or when unused or unattended for long periods. This will prevent damage to the power supply units from lightning and power line surges.

WARNING:

DO NOT TOUCH OR DISCONNECT DEVICES DURING A LIGHTNING STORM – RISK OF DEATH BY ELECTRIC SHOCK!



Voltage Selector

Make sure that the voltage selector of the power supply is set to the correct voltage **BEFORE YOU CONNECT THE POWER SUPPLY.**

Location and Accessibility of the Power Supply and the Power Cord

The power supply units must be located such that the rear AC socket and connected power cord are readily accessible.

Overload

Avoid any kind of overload in connections to wall sockets, extension or splitter power cords. Overloads create serious risk of **FIRE HAZARDS** and **DEATH BY ELECTRIC SHOCK!**

WARNING:

RISK OF DEATH BY ELECTRIC SHOCK!



Opening of Devices

Power Supply Units

Do not open power supply units. Call a qualified service technician if it is necessary to open a power supply unit. If you open a power supply yourself without we have expressly agreed in writing, we are not liable for any injury or damage!

If you by any means decide to ignore this warning, **DO NOT OPEN THE HOUSING OF A POWER SUPPLY UNIT BEFORE YOU DISCONNECT THE POWER CORD.** Even if the unit is switched off, dangerous voltage is present inside the unit! In order to avoid exposure to any residual voltage, the units should be disconnected from any power source at least 5 minutes before opening!

Opening power supply units without removing the power cord can



cause death by electric shock!

WARNING:
RISK OF DEATH BY ELECTRIC SHOCK!



ToolMix and/or ToolMst Units

You may need to open a ToolMix8, ToolMix16, ToolMix32, or ToolMst device to change the configuration using jumpers that are located inside these modules. Before you open one of these devices, make sure that you switch off and disconnect the power supply unit that is attached to the particular device! The supply voltages of +/- 25 volts and 48 volts DC are accessible inside the frames. Although these voltages are low, there is still the risk of electric shocks.

Wait at least 5 minutes after disconnecting the power supply before you open the unit to avoid any exposure to residual voltage. Otherwise, no liability will be assumed.

Before you reconnect the power supply and switch on, make sure that all units are closed and that no objects are left in the units!

Do not make any modifications apart from the jumper settings.

Sharp Edges

Devices may have sharp edges that might hurt you! Make sure that you handle with care while you install units and modify jumper settings!

Fuses

Do not use different fuses for replacement. NEVER replace a fuse with another one with higher current values or different tripping behavior. Use only fuses with the original values. Other fuses can cause **DAM-**

AGE, FIRE, and/or ELECTRIC SHOCKS.

WARNING:
RISK OF DEATH BY ELECTRIC SHOCK!



Ventilation Slots

Ventilation slots and/or openings prevent the devices from overheating. **Do not block or cover ventilation openings.** Never place the units on a soft surface (carpet, sofa, pillow, etc.). Make sure to provide enough space (4 to 5 cm / 2 inches) around the devices, when mounting into a rack or cabinet.

Modifications

Do not make any modification to the units without express written approval from the adt-audio Karl Juengling! Your life is in danger! **We are not liable for any damage or injury resulting from unauthorized modifications.**

Repairs

In case that:

- you think that repairs are necessary
- objects or fluids have gotten into a device
- the device fell to the ground
- the device is otherwise mechanically damaged
- the device is not working properly
- the power cord is damaged
- the device was exposed to rain
- the device fell into water

Disconnect the power immediately and contact a qualified service



technician.

Make sure to inform the service technician about anything that has happened to the device.

In case that the power cord is damaged, do not touch the cord or the device but switch of the main circuit breaker before disconnecting the power cord.

WARNING: RISK OF DEATH BY ELECTRIC SHOCK!



Spare Parts

Make sure that only original parts are used for repair or replacement. Wrong spare parts may cause **fire**, **electric shocks**, **subsequent damages**, and other **dangerous risks**. Otherwise, the warranty is void and no liability will be assumed.

Safety Test

Insist that the service technician conducts a thorough safety test to ensure that the condition of the repaired device is safe and up to factory standards.

Factory Repair

If you intend to send defective devices to the factory, please get in touch with us by phone (0049 2043 51061) or by email (support (at) adt-audio.com) and let us know:

- Type and serial number of the defective device
- Date of purchase and name of the dealer,
if you have not purchased directly from the factory

- A brief description of the problem and of the history (fluids in the device, something that happened, etc.)

We will tell you how to proceed.

Cleaning

Before you begin to clean devices, disconnect the power cord. Clean only with a dry cloth and do not use any solvents or sprays! For removing stubborn contaminations, you may use a cloth soaked with isopropyl alcohol as cleaning agent. Isopropyl alcohol does not attack the powder coating and the plastic parts.

Make sure that the alcohol is entirely evaporated before you reconnect the unit to the power line. Otherwise, you risk fire and electrical shocks!

WARNING: RISK OF DEATH BY ELECTRIC SHOCK!



The ToolMix System

Four 1U high rack-mounted units form the adt-audio ToolMix system. In addition to simple stand-alone operation of a single device, all units can be linked in any desired way to build up compact, professional mixing systems. ToolMix makes it possible to setup mixers with many channels in the size of some rack spaces at a price that is much lower than the price of a conventional console.

some basic specs:
 headroom + 30 dBu
 more than 120 dB dynamic range
 all inputs and output balanced
 the proven sound performance of the well known
 adt-audio large format consoles

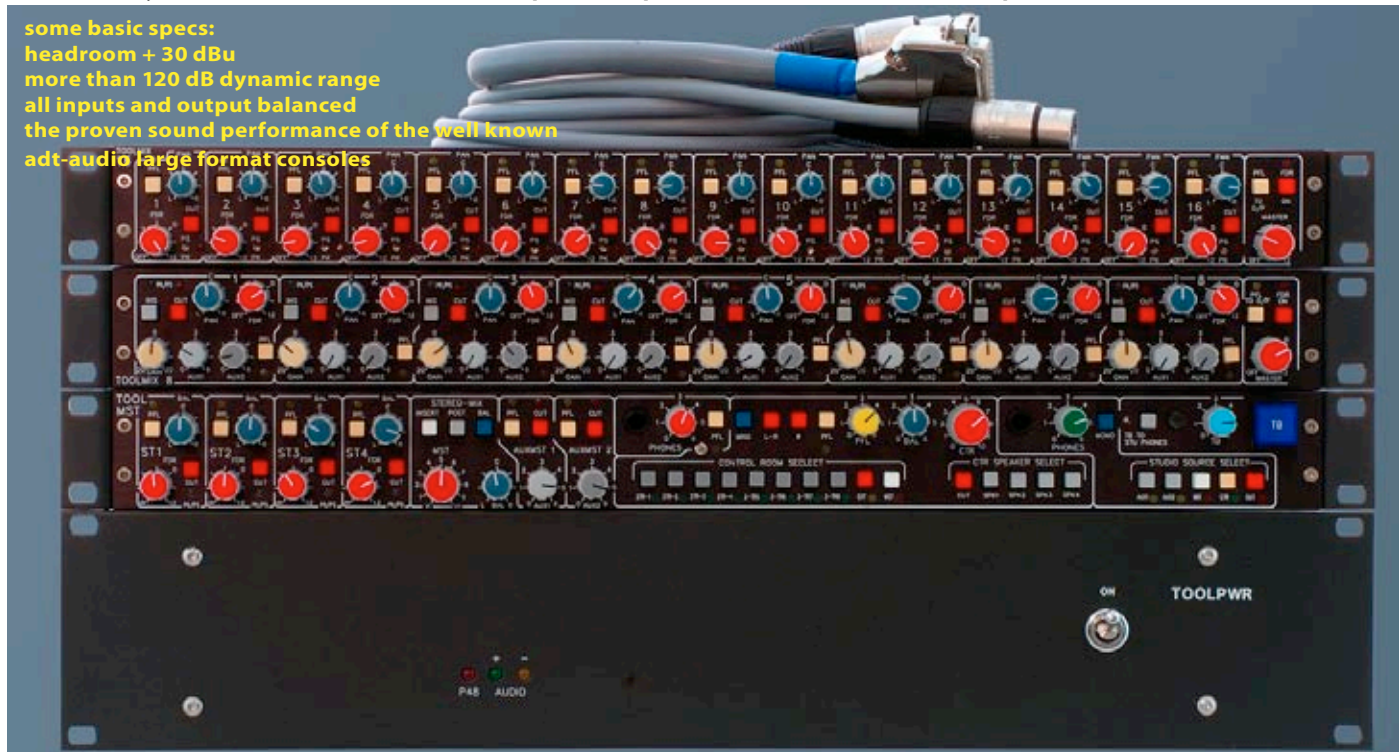



The Units

All ToolMix Units contain all necessary master amplifiers and a complete link interface to be used stand-alone, as slave, or as master for a set of ToolMix devices.

TOOLMIX8

ToolMix8 is a compact line mixer with 8 input channels with a feature set close to a conventional input channel. Each channel has a balanced input, input gain control with calibrated center position and +/- 20 dB range, a fully buffered, balanced, switched insert, a rotary fader with calibrated center position, an also calibrated pan pot, a peak present indicator, and PFL and CUT switches. In addition, there are two aux sends. The aux sends are configured pre fader; changing to post fader is possible by internal jumpers. Unlike other line mixers where the so called insert is nothing but a simple input A/B switch with a passive parallel output of one of the inputs, the ToolMix insert point is located post input amplifier and input gain control. It is fully buffered and balanced and capable to handle input and output levels of + 30 dBu. This principle allows you to control the input level of external processing gear without the need to change the DAW output level.



TOOLMIX16

ToolMix16 contains 16 mono input channels with rotary fader and pan pot, peak present indicator, and PFL and CUT switch. Unlike the ToolMix8, ToolMix16 has no input gain controls, inserts, and aux sends but 16 instead of 8 input channel. The faders and pan-pots have precisely calibrated center detents. With all pots set to center, ToolMix16 preserve the original level relations of the DAW outputs but offers the additional choice of direct analog control when necessary.



TOOLMIX32

At a glance, there is no difference between the ToolMix32 and the ToolMix16. Apart from the type name, the faceplates are identical. However, the ToolMix32 has 16 stereo inputs instead of 16 mono inputs with the ToolMix16. Therefore, ToolMix32 is the right choice if you need to mix many stereo sources.



TOOLMST

The ToolMst completes the ToolMix range of pro audio devices for mixing. In addition to four stereo inputs, this device combines all stages of a common console master section. Stereo master chain with master fader and master insert are integrated as well as a complete control room monitor, studio playback and talkback section. The ToolMst adds all function of a conventional console to a system with any number of ToolMix devices.



POWER SUPPLY UNITS

All power supply units of the ToolKit/ToolMix/ToolMod series can be used. Of course, any power supply can be used for any combination of these units up to its maximum capacity. The selection of the power supply units depends on the current consumption and the number of the existing Tool devices. ToolPwr-M is a desktop unit for 2 to 3 1U high devices; ToolPwr-S and ToolPwr-E are 2U high 19" units with higher capacity.





Cables

Cables for the power supply connections from the power supply units to the ToolMix devices and between the devices as well as link cables are available in standard length and custom length according to your needs. Standard cables 3 m / 10 ft, 1 m / 3ft, and 30 cm / 1 ft. as well as standard link cables 30 cm / 1 ft are available from stock.

Of course, we also deliver standard audio cables, patch cords with xlr, and trs connectors, and multicores with 25-pin d-sub's in different versions.

Please ask for details.





Connectors

This chapter explains the pinning of all ToolMix / ToolMst devices in detail and includes important information on the particular connectors.

The ToolMix & ToolMst devices are equipped with the following connector types:

STANDARD AUDIO CONNECTORS



3-PIN XLR - MALE
2 OUTPUT + / Phase a / hot
3 OUTPUT - / Phase b / cold
1 SCREEN connected to Ground



3-PIN XLR - FEMALE
2 INPUT + / Phase a / hot
3 INPUT - / Phase b / cold
1 SCREEN connected to Ground

ALL SCREENING PINS ARE CONNECTED TO GROUND

1/4" / 6.3 mm JACK - USED FOR PHONES

TIP	LEFT OUTPUT
RING	RIGHT OUTPUT
SLEEVE	COMMON / GROUND



3-pin XLR Connectors

These connectors are used for several outputs. The pinning meets the international standards with pin 2 = +/hot and pin 3 = -/cold. Pin 1 is the screen pin that is connected to ground.

1/4" TRS Jacks

TRS jacks are only used for the headphone outputs in the ToolMst. Pinning also meets the international standards with left channel on tip, right channel on ring and ground on sleeve.

25-pin D-Sub Connectors

All audio multipin connectors for inputs and outputs are 25-pin D-sub connectors. Female connectors are installed in the devices. All cables must have male plugs.

STANDARD AUDIO LINES ON SubD-25 CONNECTORS

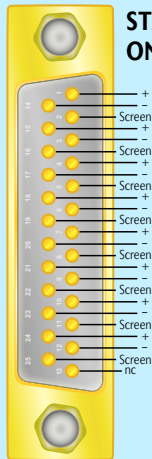

25	+	AUDIO 8
24	-	Screen
23	+	AUDIO 7
22	-	Screen
21	+	AUDIO 6
20	-	Screen
19	+	AUDIO 5
18	-	Screen
17	+	AUDIO 4
16	-	Screen
15	+	AUDIO 3
14	-	Screen
13	+	AUDIO 2
12	-	Screen
11	+	AUDIO 1
10	-	Screen
9	+	Screen
8	-	Screen
7	+	Screen
6	-	Screen
5	+	Screen
4	-	Screen
3	+	Screen
2	-	Screen
1	+	Screen

SubD-25 Connector
Female in device

The pinning of these connectors meets the so-called 'Tascam' standard. There are up to eight audio lines on one connector. The graphic shows the basic pinning. All screen pins are connected to the internal ground.



Power Supply Connections

All Tool devices use the same power supply connection with a balanced main audio supply voltage of +/- 25 volts DC. Each device has a male and a female connector to daisy chain the power supply from unit to unit. The connectors are 5-pin xlr. The power supply connectors include a 48 volts phantom power supply that is not used with the ToolMix/ToolMst units but included to keep the power supply compatible with the other ToolKit and ToolMod units.

The picture shows the rear panels of a ToolMix8 and a ToolMst, powered by a ToolPwr-M with power cables installed. A 10 ft. cable connects the output of the power supply unit with the ToolMst. A 1 ft cable connects ToolMst with the ToolMix8.



IMPORTANT NOTES ABOUT THE POWER SUPPLY:

There are no life-threatening voltages inside the Tool devices. The highest voltage is the 48 V phantom power. Special safety rules for high voltage devices are not necessary.

THIS IS OF COURSE NOT THE CASE FOR THE POWER SUPPLY UNITS!

VOLTAGES INSIDE THE POWER SUPPLY ARE DANGEROUS!

READ AND FOLLOW THE SAFETY INSTRUCTIONS ON PAGES 6 - 10 CAREFULLY

YOUR LIFE IS IN DANGER!





All Tool devices are wired by the principle that the electric ground (Audio Ground) is not connected to the chassis. The only connection between audio ground and chassis is made in the power supply unit. This principle avoids ground loops in extensive systems with many linked units. If there is a problem with hum for any reason,

DO NOT DISCONNECT THE PROTECTIVE GROUND OF THE MAINS POWER SUPPLY!

unless your local safety system uses a different principle to maintain electric safety.



FOR PROPER AND SAFE OPERATION, THE POWER SUPPLY MUST BE ALWAYS CONNECTED TO THE PROTECTIVE GROUND

The power transformers of the ToolPwr units are equipped with a special screen winding between primary and secondary. Therefore, the connection to the protective ground is not necessary for safety reasons if there is another fixed ground connection that is sufficient to maintain safety. However, you are not allowed to disconnect the protective ground! Please get in touch with us and ask for advice.

The **MAXIMUM CURRENT** of the 5-pin xlr connectors should not exceed 3 amperes. If the actual current exceeds this value, the connectors might be damaged or the lifespan and the reliability of these connectors will be reduced. In addition, the voltage drop on the power cable gets higher with more current. You can avoid all possible problems if you do not daisy chain more than 6 units.

DO NOT DAISY CHAIN MORE THAN 6 TOOL UNITS!



TOOLKIT/TOOLMIX/TOOLMOD POWER SUPPLY CONNECTORS

1	AUDIO SUPPLY - 25 V
2	PHANTOM SUPPLY + 48 V
3	AUDIO SUPPLY + 25 V
4	AUDIO GROUND
5	AUDIO GROUND
CASE	PROTECTIVE GROUND

PROTECTIVE GROUND AND CHASSIS ARE CONNECTED

AUDIO GROUND AND CHASSIS ARE CONNECTED IN THE POWER SUPPLY UNIT

USE 6 PIN CABLES

ATTENTION:
 MAXIMUM CURRENT OF CONNECTORS IS 3 AMPERE

DO NOT CONNECT MORE THAN 4 TOOL DEVICES IN DAISY CHAIN MODE



The ToolPwr-M power supply device has one output connector, since its output current is limited to 1.5 amps peak output current. There is no risk to exceed the limit with this power supply unit. The Tool-Pwr-S and ToolPwr-E have two connectors in parallel.

The inrush current of the units is multiple times higher than the operation current if you install power cables with power supply on. Even though no damage can occur when you disconnect or connect power cables with power on, you are supposed to switch off the power supply unit before you plug or unplug power cables to protect the connectors and avoid triggering the overload protection of the power supply units. In case you plug in a power cord by mistake, the overload protection of the power supply may be triggered by the high inrush current. In this case, one or both audio supply voltages will not ramp up correctly. One or both control LED's on the power supply faceplate either will be off or dimmed. Heavy hum and distortion on all audio outputs will occur. In this case, switch off the power supply, wait about 2 minutes, and switch on again.

SWITCH OFF THE POWER SUPPLY BEFORE YOU CONNECT OR DISCONNECT POWER CABLES!

Power supply cables

If you do not purchase power cables from us but make these cables yourself, please use the pinning diagram. Please consider that the quality of the connectors is crucial for trouble free operation of the entire system. It makes no sense to use low cost, bad quality connectors to save some money. This will result in very unpleasant click noise and bad noise performance very soon.

CLICK NOISE AND BAD NOISE PERFORMANCE ARE MOST LIKELY

IF YOU USE LOW QUALITY POWER CONNECTORS.

Please use a 6 core cable with a cross section of 0.75 mm² / AWG18 per core. With this cross section, the voltage drop on the power cord under full load is less than 0.25 V with six units installed. This voltage drop does not alter any technical qualities of the devices. If you lower the cross section, the voltage drop increases. This causes a lower headroom and reduced transient performance.





Linking of ToolMix Units

Each ToolMix/ToolMst device has two 'COUPLE' connectors that can be used to link the bus rails of the connected units.

A special docking cable is necessary to connect two ToolMix devices. The pinning of this cable can be found on page 21. Both COUPLE connectors are in parallel in the ToolMix units. Therefore, both connectors are identical and can be used either as input or as output. All devices are daisy chained using one cable for two units.

The connections on the link bus are very low impedance, balanced, zero-ohms bus rails that make possible connecting many units without the risk of reduced noise performance and/or interferences.

Master

All ToolMix units have their own summing amplifiers and can be used stand-alone. The outputs of the internal summing amplifiers are balanced and connected to the couple connectors.

Each ToolMix unit contains an additional set of external summing amplifiers which makes it possible to use any device as master for any number of other ToolMix units, used as slaves. It is possible to mix ToolMix8, ToolMix16 and ToolMix32 units in any desired way.

However, there are some restrictions. If a ToolMst master and monitor unit is part of the entire system, this unit must be used as master. This is actually not a restriction, since the master functions that are included in the ToolMst make it self-evident to use this device as master. It would be pointless to use another device as master. For this reason it



is not possible to use the ToolMst as slave for other ToolMix units. It is obvious for such a system that no other ToolMix unit can be used in Master mode, since only one of the linked devices can be master.

There is one exception from this general rule. If a ToolMod Console is part of the entire system, the master module of the ToolMod Console will be the master of the system. If a ToolMst is part of a system with a ToolMod Console, the ToolMst can be configured by internal jumpers in a way, that the internal bus amps are disabled. Please refer to the corresponding appendix of the ToolMod Console Manual for details.

If more than one ToolMix8 device is link to ToolMix16 or ToolMix32 units, one of the ToolMix8 units must be used as master. Since there are no aux sends in the ToolMix16 and ToolMix32 there are also no summing amplifiers and outputs for aux sends in these units.

If a ToolMix16 or ToolMix32 is configured as master, the aux sends of a particular ToolMix8 devices will still operate locally but the aux bus



rails are not coupled to the other ToolMix8 units of the system. The aux outputs of the particular ToolMix8 are still available at the aux outputs but there is no common aux master for the entire system. Of course, it is possible to use this limitation for a special setup, offering the choice of separate aux outputs as well.





If a ToolMix8 is used as master, this limitation does not exist.

Unlike the ToolMix16 and ToolMix32, each ToolMix8 includes also link amplifiers for the two auxiliaries. In this case a mix of the aux sends of all ToolMix8 units are available at the aux outputs of the master device while the aux sends of the particular ToolMix8 slave units are still available at their local outputs. Of course this is also the case for the stereo master and the pfl master. If a ToolMod console is part of the system, it makes no sense to use a ToolMix unit as master anymore. If you have such a system, please make sure that none of the ToolMix units is configured as master.

The **MASTER SWITCH on the rear panel** determines the operation mode of a particular device. If the master switch is not pressed, the unit operates in slave mode. If the master switch is pressed, the internal link amplifiers are enabled and mixed to the internal masters. All connected devices will be mixed to the outputs of this device. A LED indicates if the unit operates in master mode. The master switch is not important for units that operate stand-alone; however, it is advisable to disable the master mode unless it is really needed.

Important Note:

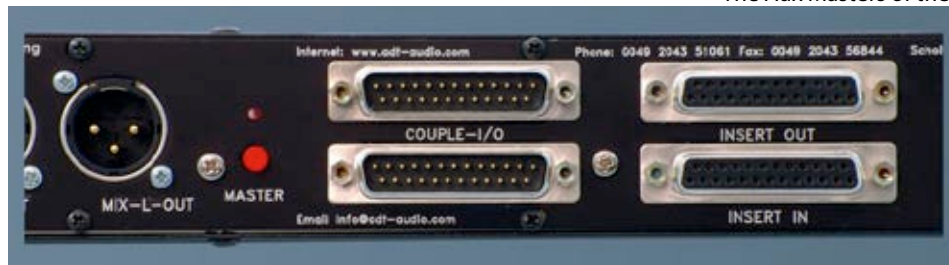

Only ONE UNIT of a group of devices that are connected by docking cables can be configured as master. If two or more units are switched to master mode, the zero ohms summing amps of these devices are connected in parallel. This will cause a drop in level of 6 dB with 2 devices and 10 dB with 3 devices and the noise performance of such system will be decreased, since the parallel summing amplifiers cause the same effect as the installation of approx. 200 additional input channels. In addition, the devices that are configured as master will not mix their own channels into the other master units. If you realize such strange behavior of your system, please check the master switches.

Master Fader

Each ToolMix unit has its own **Master Fader** for the stereo master that is activated by the FDR ON switch. This fader affects both the local master output and the link output of the unit. This makes it possible to use the master fader as **sub-group master** fader when the particular unit is used as slave device for a setup with several ToolMix with or without ToolMst.

Aux Master Faders

The Aux Masters of the ToolMix8 devices do not have their own mas-





ter faders. Therefore, the sub-group master function is limited to the stereo master.

PFL TO O/P

The **PFL TO O/P** witch reroutes the PFL output to the main stereo master output if one or more PFL switches are pressed. **DO NOT USE THIS FUNCTION IN SLAVE UNITS, UNLESS YOU EXACTLY KNOW WHAT YOU DO.** Since the PFL system is linked to the master, the output of the PFL system is routed to the stereo output of the main master if the function PFL TO O/P is activated. It is therefore not meaningful to use this function in slave devices.

Grounding

Sufficient grounding between linked devices is very important for the dynamic range and the noise performance of the entire system. The standard power supply and docking cables include a ground cross section that is more than sufficient for any standard setup as long as linked units are mounted close together, which means one above each other or next to each other in two racks. If it is necessary to install the units in a way that the length of the docking cable is more than 3 meters, it can be of advantage to add a high cross sec-

tion ground cable. The ground terminal on the rear panel can be used for this additional ground.

ToolMix8 Audio Connectors

There are separate XLR connectors for the master outputs of the Tool-



TOOLMIX & TOOLMST COUPLE

- MIX COUPLE CONNECTOR
- COUPLE BUS PFL CTRL (1 | 14)
- COUPLE BUS PFL AUDIO
- COUPLE BUS AUX 2
- COUPLE BUS AUX 1
- GROUND
- COUPLE BUS MIX R
- GROUND
- COUPLE BUS MIX L

SubD-25 Connector
Male installed in device

Mix8. The device has the standard power supply connectors and the two couple connectors. Please refer to the beginning of this chapter



for the pinning of these connectors.

All inputs and outputs of the eight audio channels are available on four 25-pin D-Sub connectors. The INPUT connector contains all inputs of the channels. The insert outputs and inputs and the optional channel outputs are electronically balanced and available on the three other D-Sub connectors. The input impedance of all inputs is higher than 10 kOhms; the source resistance of all outputs is less than 50 ohms. All screen connections are internally grounded.

If the optional outputs are not installed; this connector is not fitted and covered by a blank panel. Upgrade is possible by installing the output driver PCB and the connector. Here are pinning diagrams:

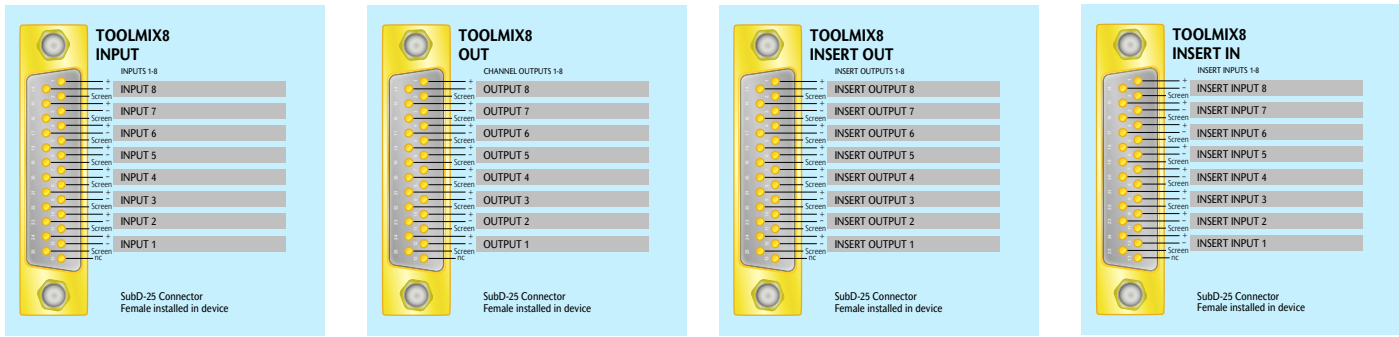



ToolMix16 Audio Connectors



There are separate XLR connectors for the stereo mix master outputs and the PFL output. Like all other Tool devices, the standard power connectors and the two couple connectors are installed. Please refer to the beginning of this chapter for the pinning of these connectors.

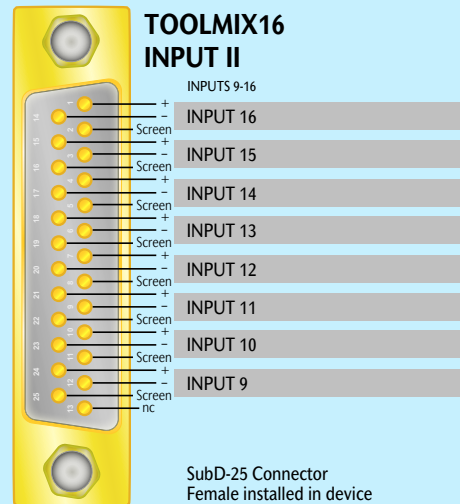
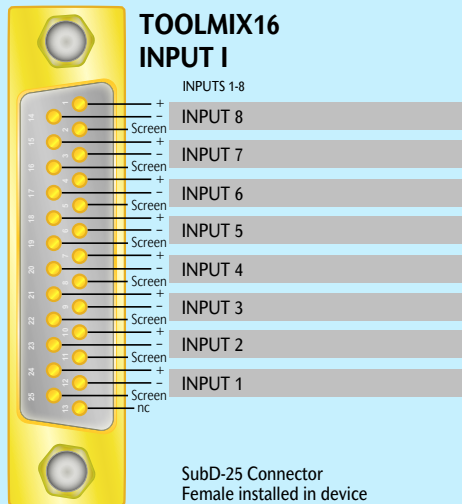

The 16 inputs of the unit are available on two 25-pin D-sub connectors, wired in 'Tascam' standard. Connector INPUT1 contains the channels 1 to 8, connector INPUT2 channels 9 to 16. All inputs are electronically balanced. The input resistance is higher than 10 kOhms. All screen pins are internally grounded. Here is the pinning of these connectors,

ToolMix32 Audio Connectors



Like the ToolMix16, the master outputs of the ToolMix32 are available on separate XLR connectors for MIX-L, MIX-R, and the PFL master. The standard power supply connectors and the 2 couple connectors are also installed. Please refer to the beginning of this chapter for the pinning of these connectors.

The inputs of the 16 stereo channels are available on four 25-pin D-sub connectors. Connector INPUT-I contains the channel 1 to 4, INPUT-II contains channels 5 to 8, INPUT-III contains channels 9 to 12 and INPUT-IV the channels 13 to 16. All inputs are electronically balanced. The input impedance is at least 10 kOhms. All screen pins are internally grounded. Here are the pinning diagrams of these connectors:

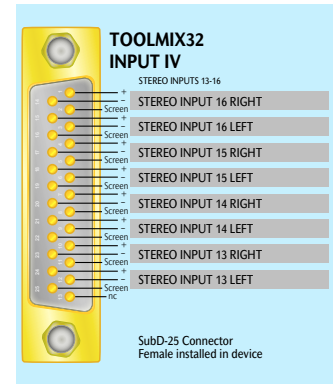
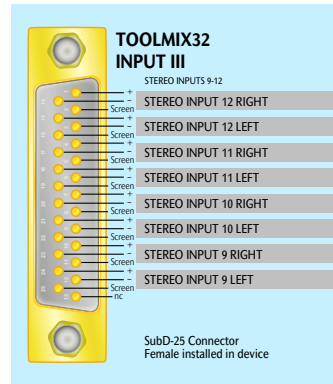
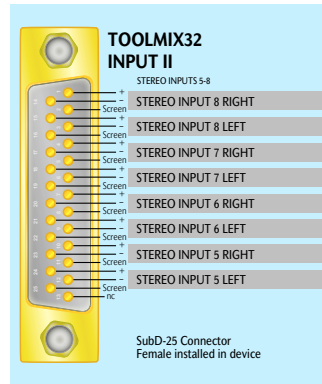
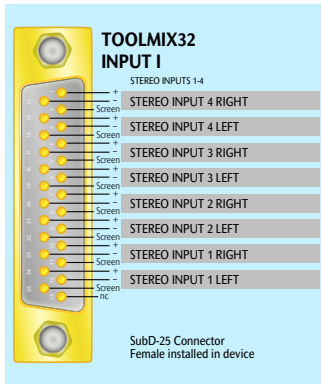

ToolMst Connectors



The outputs of the stereo master are available on separate XLR connectors. In addition to the standard power connectors and the couple connector, all the other inputs and outputs are distributed among seven 25-pin D-sub connectors. A 9-pin D-sub contains some remote connectors for DIM, talkback and more. The pinning of these connectors is described in detail below. Apart from the headphone outputs, all other audio inputs and outputs are electronically balanced. The input resistance is more than 10 kOhms; the source resistance is less than 50 Ohms. All inputs and outputs can handle levels of more than + 30 dBu.

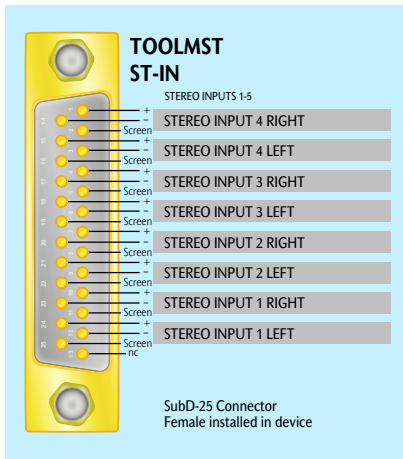

Connector ST-IN

This connector contains the inputs of the four stereo input channels according to the pinning diagram.

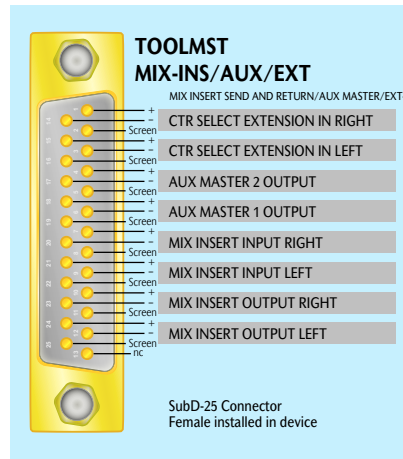

Connector MIX-INS/AUX/EXT

This connector combines the stereo master insert inputs and outputs, the aux master outputs 1 and 2 and the stereo extension input of the control room source selector.

The extension inputs feed the source select switch no. 9. Depending on the internal jumper setting of the device this input can also be used as an alternate source for the ,CTR' switch of the playback source selector.

Connector CTR SPEAKERS

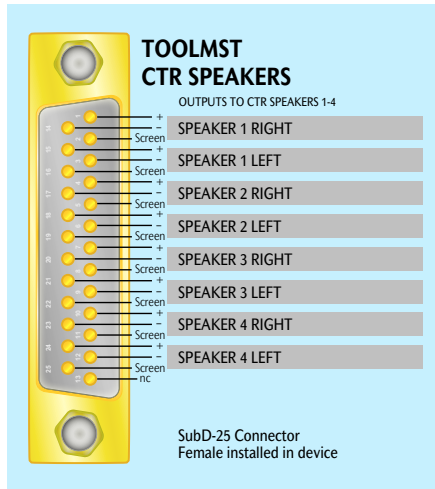

Four separate speaker systems can be installed. The outputs of these stereo control room speaker and/or amplifier systems are available on this 25-pin D-sub connector.

Connector STUDIO/PFL/TALKBACK/METER

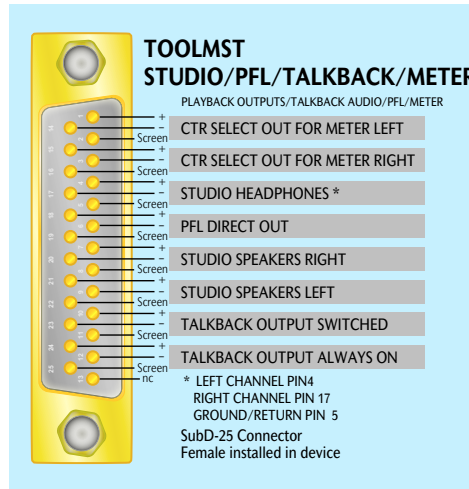

The Studio connector combines some additional inputs and outputs. The installation of an external meter is possible using the CTR SELECT OUT FOR METER outputs that are in parallel to the output of the control room source selector. In addition to the STUDIO HEADPHONE output that is suited for the direct connection of up to 3 headphones, there is a separate stereo output for studio loudspeakers, which can be muted by a control input on the remote connector. The TALKBACK OUTPUT ALWAYS ON contains the direct output of the talkback amplifier, while the 'SWITCHED' output is only active when the talkback switch is pressed. PFL DIRECT OUT is the direct output of the PFL master amplifier.

Connector 2-TR 1-4

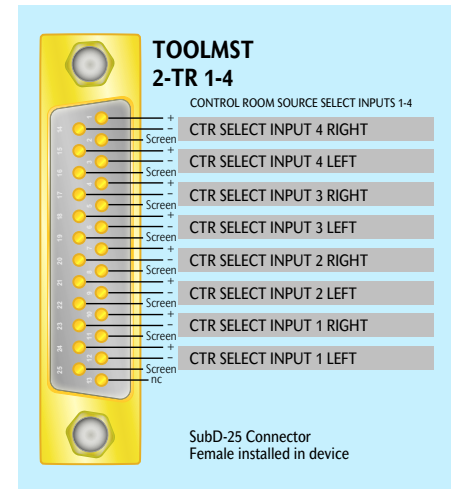

The control room source selector makes possible to connect and select up to 9 external balanced stereo devices. The connector 2TR 1-4 is the input for the stereo devices 1 to 4.



Connector 2-TR 5-8

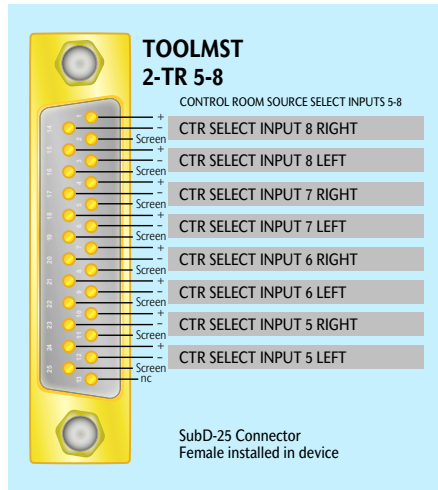

The control room source selector makes possible to connect and select up to 9 external balanced stereo devices. The connector 2TR 5-8 is the input for the stereo devices 5 to 8.

Connector REMOTE

This female 9-pin D-sub connector combines some important remote control inputs and outputs. All inputs and outputs are ,active low'. All outputs are open collector outputs that can drive up to 100 mA. The maximum voltage is 30 V DC.

IMPORTANT NOTE:

To avoid any kind of disturbance and click noise caused by ground loops, please use FLOATING relays, switches, opto couplers and other components only. The external circuitry may not be connected to an external ground of another device. Use relays or opto couplers for such connections to separate the grounds. A 24 V DC supply voltage is available on pin 6 of the connector. This voltage can be used for such external components. A self-releasing fuse limits the output current to 100 mA. The source resistance of this voltage is 50 ohms. If the output was shorted please remove the plug and reinstall it after approx. 10 seconds to reset the internal fuse.

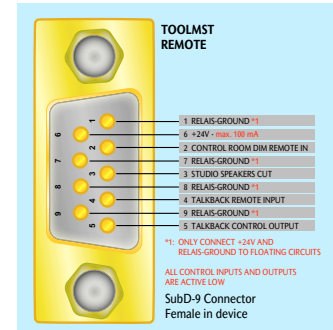

Studio Speaker Cut

When this input is connected to one of the RELAY-GROUND pins, the outputs of the studio speakers are muted. The studio headphone outputs are not affected.

Control Room Dim Remote In

When this input is connected to one of the RELAY-GROUND pins, the control room DIM becomes active. Only the control room speakers are affected; the control room headphone output will not be attenuated. This function makes possible to couple the ToolMst to external talkback systems.

Talkback Remote Input

External talkback switches or controls can be installed on this pin. When this pin is connected to one of the RELAY-GROUND pin talkback is on.

Talkback Control Output

This output is low when talkback is active



The ToolMst Console I/O Connector

This connector is available from revision 2.1 of the ToolMst. In combination with internal jumpers, it makes it possible to use a ToolMst in combination with a ToolMod Console. With the Console, the main stereo master amplifiers and the auxiliary masters 1 and 2 as well as the PFL master and the control system must be in the master module of the console and not in the ToolMst as it is the case in linked ToolMix systems. Jumpers on the ToolMst PCB's to this additional input connector can reassign the internal connections of these signals.

Unlike the standard audio connectors, this 25-pin D-sub is a male version, like the couple connector. **Please note that installation of a cable to this connector will end in strange behavior of the ToolMst unless you make sure that ALL internal jumpers are set to ,Console' mode.** Please refer to the jumper location plots of your technical manual. If you do not have these drawings, send an email including your name and the serial number of the ToolMst to support@adt-audio.com and ask for the jumper location plots.

Here is a brief description what needs to be done, what the purpose of the lines on the connector are and which jumpers are affected.

A set of jumpers has to be removed or reconfigured respectively, if the couple connector of the ToolMst is used. This will usually be the case, just for the reason that the 4 return inputs in the ToolMst can be used as additional inputs. If there is no cable installed in the COUPLE I/O connector, you can ignore the following marks.

- The internal bus amps for mix left, mix right, aux 1, aux 2, and pfl must be disabled. In addition, the mix left and mix right pins on the

couple connector must feed the sum of the internal channels to the couple port instead of receiving signals from other modules. The jumpers JU11 to JU14 reassign the stereo master pins. These 3-pin jumpers have to be reversed (bridge pin 2 and 3 instead of pin 1 and 2). The jumpers JU15 to JU19 are 2 pin jumpers. These jumpers have to be removed to disconnect the internal bus amps for aux 1 & 2, pfl and the pfl control chain from the couple port. All these jumpers are located on the left main pcb of the device.

Console Mix Out L balanced & Console Mix Out R balanced

With the standard setting the MST switch of the control room source selector is internally connected to the stereo master output. This makes no sense if a console is part of the system, since the master module of the console must be the master of the entire system. It is therefore necessary to feed this select switch from the stereo master outputs of the console.

The four 2-pin jumpers JU21 to JU24 that are located on the solder side of the right main pcb have to be removed to disconnect the internal master outputs left and right from the source select switch.

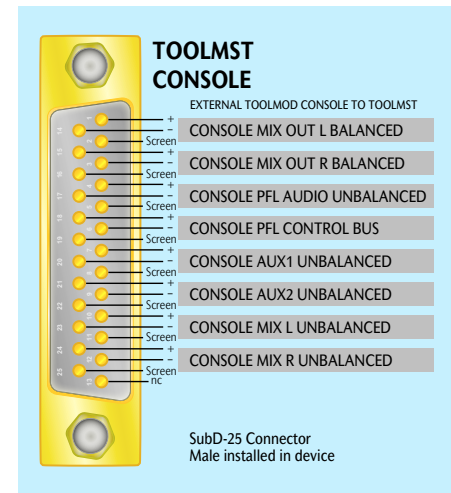



Console PFL Audio unbalanced

The standard setting uses the output of the internal PFL bus amp to feed the PFL circuit of the control room regulator section. This internal signal has to be replaced by the PFL signal of the console. This line is unbalanced. The + phase is the audio line, the - phase is connected to ground. Please reverse 3-pin jumper JU29 (connect pin 2 and 3 instead of pin 1 and 2).

Console PFL Control Bus

The standard setting uses the internal control master signal to switch over to PFL. This internal signal has to be replaced by the PFL control signal of the console. This line is an unbalanced DC line. PFL is active if a 24 V DC signal with a source resistance of 22 kOhms is applied to the bus. The + phase is the control line, the - phase is connected to ground. Please reverse 3-pin jumper JU28 (connect pin 2 and 3 instead of pin 1 and 2).

Both PFL jumpers are located on the right main pcb, next to the left border of this pcb.

Console AUX1 unbalanced, Console AUX2 unbalanced

With the normal setting, internal unbalanced outputs of the auxiliary master outputs feed the two AUX switches of the playback source selector. These outputs have to be replaced by the corresponding signals of the console. These lines are also unbalanced. The + phases are the audio lines, the - phases are connected to ground. Please reverse 3-pin jumper JU25 for Aux1 and JU26 for Aux2 (connect pin 2 and 3 instead of pin 1 and 2).

Console MIX L unbalanced, Console MIX R unbalanced

With the normal setting, internal unbalanced outputs of the stereo master outputs feed the MIX switch of the playback source selector. These outputs have to be replaced by the corresponding signals of

the console. These lines are also unbalanced. The + phases are the audio lines, the - phases are connected to ground. Please reverse 3-pin jumper JU27 for Mix left and JU28 for Mix right (connect pin 2 and 3 instead of pin 1 and 2).

If you use this port with another console

All unbalanced inputs required a phase-reversed signal of low source impedance that can be loaded with 10 kOhms. The nominal level should be in the range of 0 dBu. The balanced control room source select input MIX OUT L & R requires a standard high level balanced input signal.

More configurable Options

In addition to the settings described above, there are some other settings. All these jumpers are located on the component side of the right main pcb.

DIM-TB

The DIM-TB jumper JU31 between the mono switch and the TB to Studio switch enables that active talkback dims the control room speakers. Remove this jumper that is normally installed to disable this function.

DIM-REMOTE

The DIM remote control is enabled by default. Jumper JU32 must be removed to disable the function.

Studio CTR Switch

The studio CTR switch is fed by the control room source by default. Reversing jumpers JU33 and JU34 assigns this switch to the control room extension input EXT.

ToolMix8

8 Channel Line Mixer with Input Gain, Insert and 2 Auxiliaries



The ToolMix8 has 8 identical line inputs. All inputs are electronically balanced and can handle levels of more than + 30 dBu. A pot with calibrated center detent controls the input gain. The gain control range is +/- 20 dB. The buffered, electronically balanced insert point is driven from the output of the input amplifier. The insert output is always available on the connector panel. The insert input is switched into the signal chain when the INS switch is pressed.

Unlike other line mixers that have a simple, passive input selection using only a switch, the ToolMix8 has input amplifiers with gain control and an insert section with balanced drivers that is located post the input gain. It is therefore possible to control the level that is sent to an external processing device independent of the output level of the D/A converters. The D/A converter level can remain on the original high level while the processing device is driven by a different level.

The output of the insert switch feeds the fader, the peak present indicator, the PFL switch and the two aux sends in parallel. Both aux sends default to pre fader; however, internal jumpers make it possible to set one or both aux sends post fader as well. The peak present indicator is a 3 color led that displays levels of more than - 20 dBu with green color. The color becomes yellow at 0 dB and changes via orange to red when the level increases. With red color, the remaining headroom is still 5 dB. The post fader output is driven by the output of the channel fader, pre CUT switch. This output can be used to record the input signal directly. With this operation

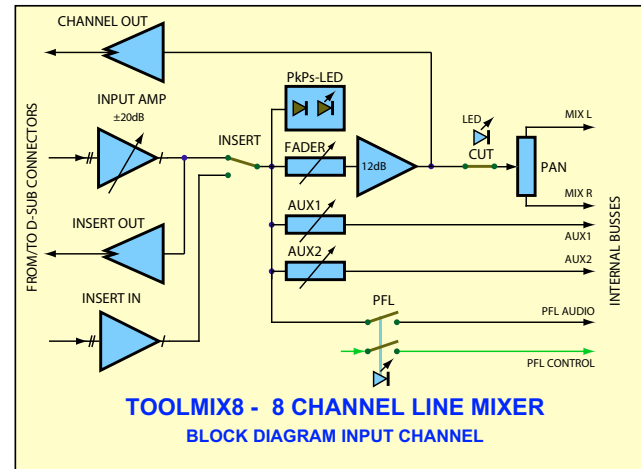



mode, the cut switch is used to exclude the particular channel from the mix master while the post fader output is still active. The block diagram shows the circuitry of one input channel.

The input fader is a rotary pot with calibrated center detent. Due to the precise calibration of the faders and pans by internal trimpots, it is possible to mirror a DAW mix to the analog channels without the need to readjust levels. Alternatively, it is also possible to set the mixing levels and pan positions directly on the ToolMix8 faceplate and make an analog mix. With this mode, the maximum output level of the converters can be used to maintain the best possible sound performance. It is self evident that the automation system of a DAW cannot be used with this method anymore.



Since the ToolMix8 offers both ways, you can decide from mix to mix and from channel to channel which method is the best for the particular purpose. In addition, it is possible to readjust particular levels directly without the need to change the DAW mix to correct level changes that are produced by analog processing devices. If analog dynamics processors are used, a level correction in the DAW would be pointless anyway, since it would change only the D/A converter output level and therefore the input level of the dynamics units. This results in a different dynamic treatment but not in a simple level correction. The huge gain range of 12 dB for the channel fader is more than sufficient for all applications. A special, active gain control makes this range possible without negative influence on the noise performance.

The input gain in calibrated position is 0 dB. Since the insert section is driven directly from the output of the input amplifier, the insert level matches the input level, when the input gain is set to the calibrated position. The calibrated position of the channel fader is - 4 dB. This level setting results in a mix output level that is almost identical to the converter output level of a single channel with almost all music mixes, since it compensates the raise in level due to mixing. This principle makes possible to set the output levels of the DA converters to the highest possible value to maintain best possible performance. The headroom of the Toolmix is at least 10 dB higher than the output level of commonly used converters. Even with analog processing gear that adds some dB to the level, there is no risk of distortion or overload in the entire signal chain from D/A converter output to the mix output. The center attenuation of the pan pot is 0 dB, which makes mirroring of DAW mixes easy, as there is no change in level if it is set to the left or the right channel only or if it feeds both the channels in mono. The control law of the pan maintains pure direction control. The cut switch mutes the entire channel but not the post fader output. The picture on this page shows the control elements of the channels 7 and 8 and the master output section.



DAW Recording

In addition to mixing, which is the main purpose of the ToolMix8, it is possible to use either the insert section or the optional post fader output for DAW recording. If an analog input amplifier or a line level source is connected to the line input of a ToolMix8 input channel the insert output is driven by this input signal. If you connect the insert output to the DAW record input, recording is possible while the input gain control of the ToolMix8 can be used to set the record level. Monitoring the DAW channel is still possible if the DAW output is

connected to the insert input. In this case, the Insert switch works just like a 'pre - post DAW' switch. With Insert switch not pressed, the input signal feeds the mix master, while the DAW output signal feeds the mix master if the Insert switch is pressed. Of course, this method will not substitute a console with sub groups or record routing system, but it is an easy way to accomplish DAW recording from time to time without the need to rearrange the entire system. However, a patch bay for the analog inputs and outputs of the DAW and the mixer are necessary for hassle-free setup of the necessary connections. The block diagram shows the principle of this operation mode.

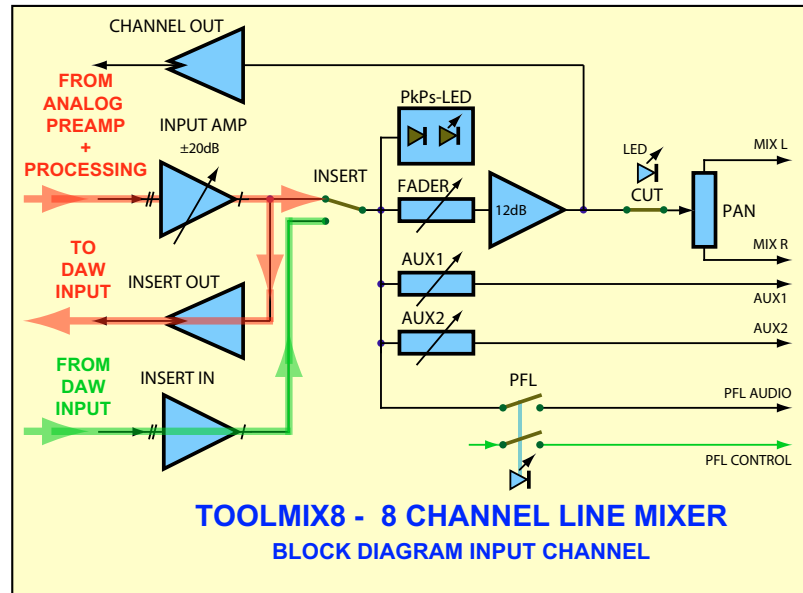

If monitoring using the same analog input channel is not needed, the optional post fader output can also be used for DAW recording. In this case, the input signal is also connected to the line input of a ToolMix8 channel, but the DAW A/D converter input is driven from the post fader output. Any kind of additional processing gear can be included using the insert. When the CUT switch is not pressed, the input signal drives the DAW input and the mix bus in parallel. During the recording, the CUT switch can be used to mute the way into the mix bus while the post fader output, which is used for recording, is still active.

Outputs

Each channel has an insert output and the channel / post fader output. The master section of the device has 5 electronically balanced outputs. All outputs can handle levels of more than + 30 dBu. The master outputs are available on separate XLR connectors. The output of the Aux1 and Aux2 masters and the PFL output are calibrated to



0 dB. The outputs of the stereo master MIX can be used without or with the master fader. If the master fader is inserted by the FDR ON switch, it operates as master level control for the output and the couple port as well.

The PFL master can be switch to automatic switch over mode by the PFL TO O/P switch. When this switch is pressed, one or more active PFL's switch the main output automatically to the PFL master.

Linking

If a ToolMix8 is used as slave module, the master fader operates like a sub group fader for the channels of the particular ToolMix device.

The ToolMix8 line mixer can be used stand alone as well as coupled to other ToolMix8, ToolMix16, and ToolMix32 units and in combination to the ToolMst.

The block diagram on the next page shows the wiring of the internal circuitry and the couple port.





Technical Data ToolMix8

Inputs:

8 line inputs, 8 insert inputs
electronically balanced, nominal level + 6 dBu
maximum input level > + 30 dBu, input impedance > 10 kOhm,
CMRR according to IRT > 75 dB from 10 Hz to 1 kHz and > 65 dB to 15 kHz

Outputs:

8 insert outputs, 8 optional channel outputs,
5 master outputs for MIX L, MIX R, AUX1, AUX2 and PFL
electronically balanced, nominal level + 6 dBu
maximum output level > + 30 dBu, source resistance < 50 ohms
CMMR according to IEC, > 50 dB from 10 Hz to 1 kHz and > 40 dB at 15 kHz
Load reaction, capacitive load, etc.: see Appendix

Gain:

Input to insert output > +/- 20 dB range, center position calibrated to 0 dB
Input in calibrated position or insert input to master output,
Fader and pan at maximum > + 12 dB, fader and pan calibrated - 4.0 dB

Frequency Response:

Line input to master output, 10 Hz to 40 kHz +/- 0.1 dB, 200 kHz - 4 dB (internal RF Filters)

Phase Response:

Line input to master output
10 Hz <+ 6°, 20 Hz <+3°, 40 Hz <+1°, 10 kHz <-3°, 20 kHz <-10°

THD:

Line input to master output, 10 Hz to 20 kHz,
level < +30 dBu: < 0.1 %, level+ 20 dBu: < 0.03%

Crosstalk:

Input channel to input channel, 20 Hz to 20 kHz > 80 dB
Fader attenuation, 20 Hz to 4 kHz > 80 dB, 20 kHz > 70 dB
CUT switch attenuation, 20 Hz to 20 kHz > 80 dB

Signal to Noise Ratio:

Input source resistance 40 ohms, bandwidth 22 Hz - 22 kHz,
reference level 0 dBu = 0.775V
dBA Values with A type weighting filter, dBu values unweighted, RMS

Line input to insert output, gain 0 dB, -100 dBA / - 95 dBu
Line Input to insert output, gain +20 dB, -90 dBA / - 86 dBu
Mix out L or R, all 8 channels open, gain and fader in calibrated positions,
-95 dBA / - 91 dBu
like above, all inputs CUT, -96 dBA / - 92 dBu
Aux out 1 oder 2, PFL, -95 dBA / -91 dBu

Dynamic Range:

Input source resistance 40 ohms, bandwidth 22 Hz - 22 kHz,
max. output level - noise voltage
dBA Values with A type weighting filter, dBu values unweighted, RMS

Line input to insert output, gain 0 dB, 130 dBA / 125 dBu
Line input to Insert output, gain +20 dB, 120 dBA / 116 dBu
Mix out L or R, all 8 channels open, gain and fader in calibrated positions,
125 dBA / 121 dBu
like above, all inputs CUT, 126 dBA / 122 dBu
Aux out 1 oder 2, PFL, 125 dBA / 121 dBu

Current Consumption

see remarks in chapter, Power Supply Units,
quiescent Current < 500 mA, Power Consumption < 25 Watt
(With high output levels and low impedance load (600 Ohms) the current consumption increases by 35 mA per output.)

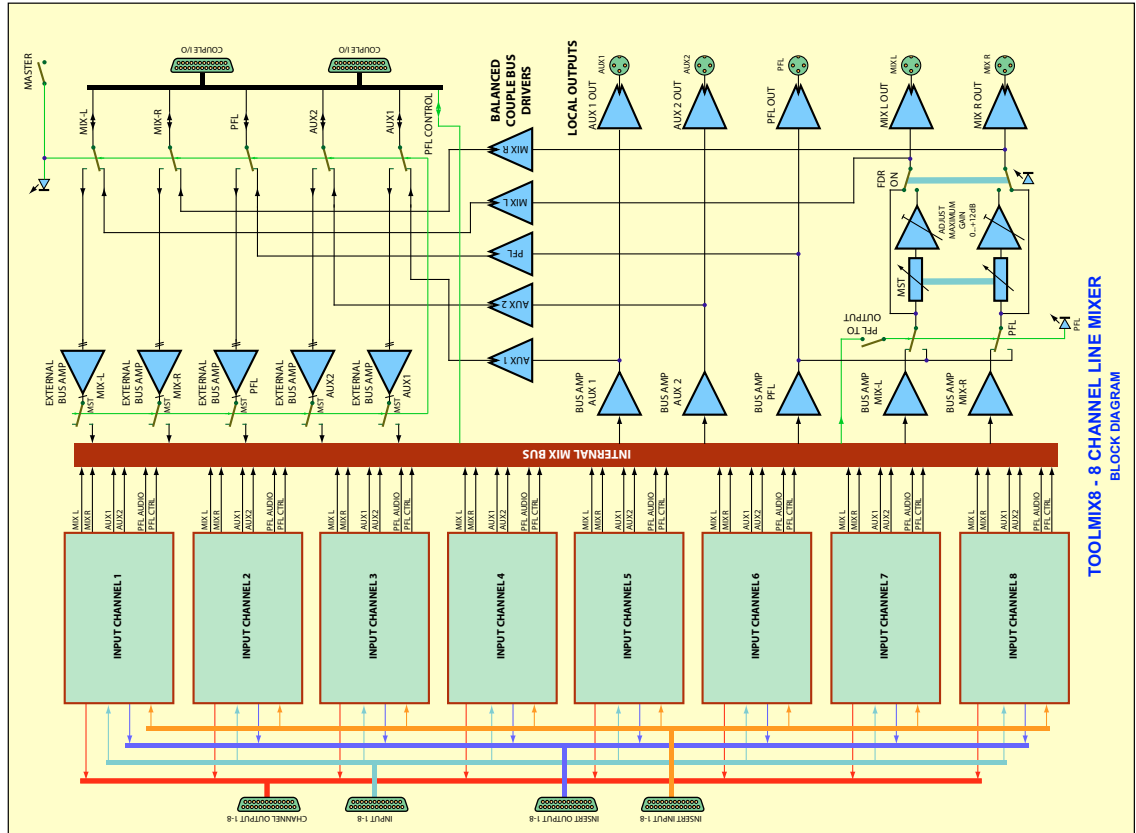

ToolMix16

16-Channel Adder with Fader and Pan



Unlike the ToolMix8, the ToolMix16 has 16 mono inputs that have no input gain controls, inserts, and auxiliaries. All available space on the top plate is used for the controls of the 16 input channels. All inputs are identical. The inputs are electronically balanced and can handle levels of more than + 30 dBu. Fader, peak present indicator, and PFL switch are driven from the fader input in parallel. The peak present indicator uses a 3-color LED that displays levels of more than - 20 dB with green color. The color becomes yellow at 0 dB and changes via orange to red with increasing level. When the LED is red, the remaining headroom is 5 dB. The block diagram shows one of the 16 input channels in detail.

The channel fader is a rotary pot with calibrated center detent, just in the same way as in the ToolMix8. Due to the precise calibration of the faders and the pan pots, it is possible to mirror a DAW mix without the need of readjusting levels. However, it is alternatively possible to setup the mix using the level and pan controls of the ToolMix unit. Of course, you are not able to maintain the mix setting of the DAW using this method but the maximum dynamic range of the D/A converters can be used, which can result in a better sonic performance. There is no basic rule which principle offers the better results, but the design principle of the ToolMix devices let's you decide from mix to mix and from channel to channel which

way is best for this particular situation. In addition, the level controls make it possible to readjust the levels of particular channels in ‚calibrated‘ mode when analog processing gear causes different levels of the channels that are treated with such devices without the need to alter the DAW mix. In case that the analog devices are dynamics processors, it is not possible to change levels in the DAW anyway, since

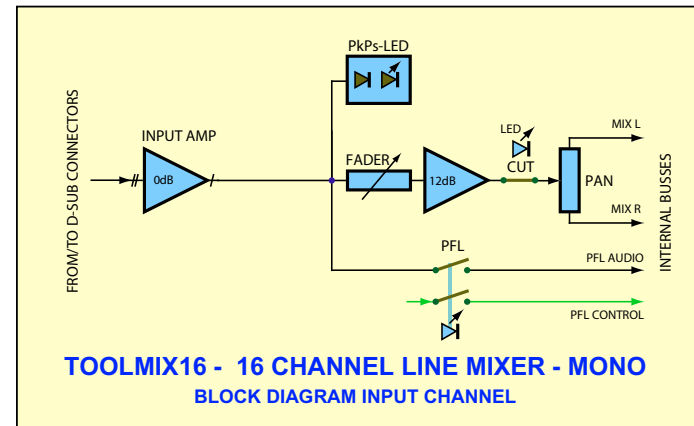



it would only change the input level of the dynamics device, which changes the dynamics treatment but not the output level. The gain range of 12 dB maximum gain is more than sufficient for all applications. A special active gain control makes this high gain possible without significant disadvantages of the noise performance.

The gain of the input amplifiers is 0 dB. The center detent of the fader is calibrated to - 4 dB. This level setting results in a total level at the master outputs that is almost identical to the single input levels with most real-world music programs. In addition, this principle has the advantage that it is possible to set the D/A converters to the highest possible output level without the risk of overload at any point of the analog system, even if some channels use high gain settings. The center attenuation of the pan pot is 0 dB. The law of regulation is optimized for pure direction control without altering the level relations.

The CUT switch mutes the entire channel but not PFL. The picture shows the control elements of some channels and the master section.

The 16 channel summing adder ToolMix16 can be used as stand-alone device as well as master or slave of a system with several ToolMix units. See the chapter about linking for details on this.

Outputs

There are 3 electronically balanced outputs that can handle levels of more than + 30 dBu. The outputs are available on separate XLR connectors. The PFL master output is

calibrated. The stereo master MIX is calibrated by default. A rotary mix master fader can be inserted by the FDR ON switch. In addition, the switch PFL TO O/P makes possible to switch over the PFL master to the main stereo output when one or more PFL switches are pressed. This function offers useful operation of the PFL system with a stand-alone device. The PFL signal is switched into the master output pre the master fader insert section.

Linking

If a ToolMix16 is used as slave unit in a coupled system, the master fader can operate as a sub group master for the channels of the particular device, since the couple port is fed post the master fader insert point.

The block diagram on the next page shows the connections of the output section and the couple port.





Technical Data ToolMix16

Inputs:

16 mono line inputs, electronically balanced, nominal level + 6 dBu
maximum input level > + 30 dBu, input impedance > 10 kOhm,
CMRR according to IRT > 75 dB from 10 Hz to 1 kHz and > 65 dB at 15 kHz

Outputs:

3 master outputs for MIX L, MIX R and PFL
electronically balanced, nominal level + 6 dBu
maximum output level > + 30 dBu, source resistance < 50 ohms
CMRR according to IEC, > 50 dB from 10 Hz to 1 kHz and > 40 dB at 15 kHz
Load reaction, capacitive load, etc.: see Appendix

Gain:

Input to master output,
fader and pan at maximum > + 12 dB
fader and pan in calibrated positions - 4.0 dB

Frequency Response:

Line input to master output
10 Hz to 40 kHz +/- 0.1 dB, 200 kHz - 4 dB (internal RF Filters)

Phase Response:

Line input to master output
10 Hz <+ 6°, 20 Hz <+3°, 40 Hz <+1°, 10 kHz <-3°, 20 kHz <-10°

THD:

Line input to master output, 10 Hz bis 20 kHz,
Level < +30 dBu: < 0.1 %,
Level + 20 dBu: < 0.03%

Crosstalk:

Input channel to input channel, 20 Hz to 20 kHz > 80 dB
Fader attenuation, 20 Hz to 4 kHz > 80 dB, 20 kHz > 70 dB
Cut switch attenuation, 20 Hz to 20 kHz > 80 dB

Signal to Noise Ratio:

Input source resistance, bandwidth 22 Hz - 22 kHz,
reference level 0 dBu = 0.775V
dBA values with A type weighting filter, dBu values unweighted, RMS

Mix out L or R, all 8 channels open, gain and fader in calibrated positions,
-90 dBA / - 86 dBu
like above, all inputs CUT, -95 dBA / - 90 dBu
PFL, -90 dBA / -86 dBu

Dynamic Range:

Input source resistance, bandwidth 22 Hz - 22 kHz,
max. output level - noise voltage
dBA values with A type weighting filter, dBu values unweighted, RMS

Mix out L or R, all 16 channels open, gain and fader in calibrated positions,
120 dBA / 116 dBu
like above, all inputs CUT, 125 dBA / 120 dBu
PFL, 120 dBA / 116 dBu

Current Consumption

see remarks in chapter, Power Supply Units,
quiescent Current < 500 mA, Power Consumption < 25 Watt
(With high output levels and low impedance load (600 Ohms) the current consumption increases by 35 mA per output.)

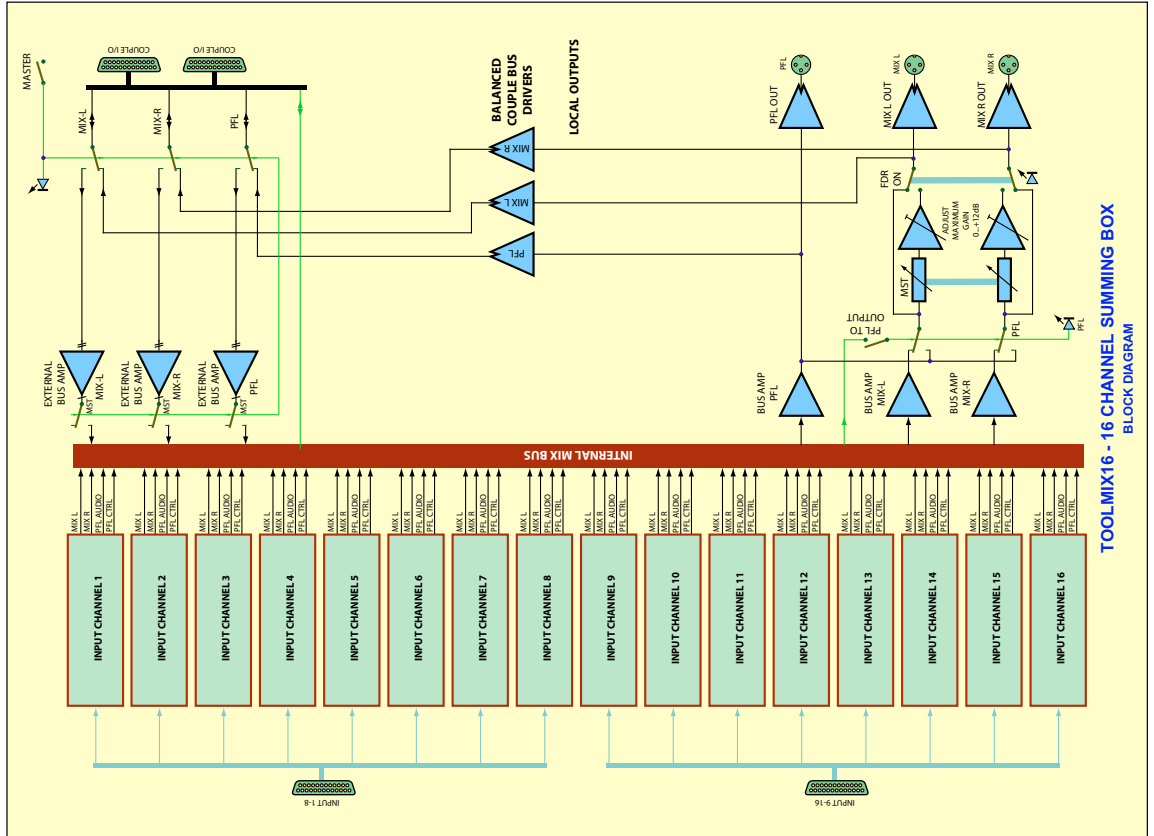

**TOOLMIX16 - 16 CHANNEL SUMMING BOX
BLOCK DIAGRAM**

ToolMix32 16-Kanal Stereo Adder with Fader and Pan



As far as the control elements on the faceplate are concerned, there is no difference between the ToolMix16 and the ToolMix32. Apart from the type name, the faceplates of both devices are identical. Unlike the ToolMix16, the ToolMix32 has 16 stereo inputs instead of mono inputs. This makes possible to handle twice the number of inputs signals. For this reason, the ToolMix32 is well suited to extend the number of channels of an analog mixing system. The price difference between the ToolMix32 and the ToolMix16 is not significant since the additional expense is limited to the stereo input amplifiers. All the rest is the same. Due to the low price difference, the ToolMix32 might also be an alternative to a ToolMix16 since it is possible to use any number of inputs in Mono just by paralleling the left and right inputs of the particular channels. However, unlike the ToolMix16, using channels in stereo mode is possible.

All inputs are electronically balanced and can handle levels of more than + 30 dBu. Fader, peak present indicator, and PFL switch are fed directly from the output of the input amplifiers. The PFL system adds both stereo channels to a mono signal. The peak-present indicator uses a 3-color LED that displays levels of more than -20 dB with green color. At 0 dB the color turns to yellow and changes via orange to red with increasing level. With red color, the remaining headroom is

5 dB. The indicator displays the level of the stereo channel with the higher actual level. The block diagram shows one of the 16 internal input channels.

Like with the ToolMix8 and the ToolMix16, the fader is a rotary pot with calibrated center detent. Due to the precise calibration of the faders and the pan pots, it is possible to mirror a DAW mix to the analog channels without the need to readjust levels. However, it is alternatively possible to setup a mix using the level and pan controls of the ToolMix unit. Of course, you are not able to maintain the mix setting of the DAW using this method

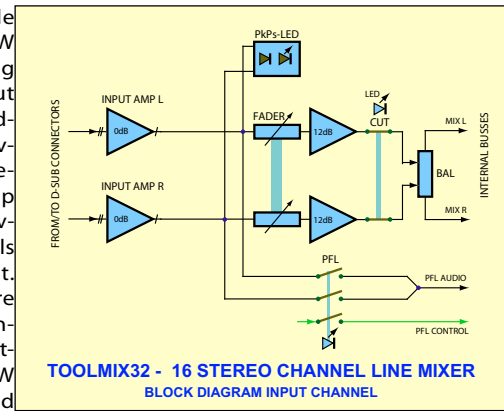



but the maximum dynamic range of the D/A converters can be used, which can result in a better sonic performance. There is no basic rule which principle offers the better results, but the design principle of the ToolMix devices let's you decide from mix to mix and from channel to channel which way is best for this particular situation. In addition, the level controls make it possible to re-adjust the levels of particular channels in ,calibrated' mode when analog processing gear causes a different level of the channels that are treated with such devices without the need to alter the DAW mix. In case that the analog devices are dynamics processors, it is not possible to change levels in the DAW anyway, since it would only change the input level of the dynamics device which changes the dynamics treatment but not the output level. The gain range of 12 dB maximum gain is more than sufficient for all applications. A special active gain control makes this high gain possible without significant disadvantages of the noise performance.

The input gain is 0 dB. The center position of the channel faders is calibrated to - 4 dB. This setting compensates the additional level of a standard music mix so the mix output level is almost identical to the output levels of the single channels. Using this principle makes possible to use the highest possible D/A converter output levels without the risk of distortion and overload, even with high gain settings in particular channels, which might offer a better sound performance of the converters. The center attenuation of the pan pot is 0 dB. The control law is optimized for a pure direction regulation without altering the level. The CUT switch mutes the entire channel but not the PFL switch. The picture shows the control elements of some channels and the master output section. The 16 channel stereo adder ToolMix32 can be used stand-alone and as master or slave of a system with several ToolMix units. See the chapter Linking' for details on this.



Outputs

The ToolMix32 has 3 electronically balanced outputs that can handle levels of more than + 30 dBu. The outputs are available on separate XLR connectors. The PFL output is calibrated. The stereo mix output can be used in calibrated mode or uncalibrated mode in combination with the master fader that can be inserted by the FDR ON switch. The switch PFL TO O/P makes possible to switch the PFL master to the mix output when one or more PFL switches are pressed. The PFL signal is inserted pre the master fader insert.

When a ToolMix32 is used as slave unit in a system of linked ToolMix units, the master fader can operate as sub group master for the channels of the particular device, since the master fader insert is located pre the couple port.

The block diagram on the next page shows the wiring of the master section and the couple port.



Technical Data ToolMix32

Inputs:

16 stereo line inputs,
elektronically balanced, nominal level + 6 dBu
maximum input level > + 30 dBu, input impedance > 10 kOhm,
CMRR according to IRT > 75 dB from 10 Hz to 1 kHz and > 65 dB at 15 kHz

Outputs:

3 master outputs for MIX L, MIX R, and PFL
elektronically balanced, nominal level + 6 dBu
maximum output level > + 30 dBu, source resistance < 50 Ohm
CMRR according to IEC, > 50 dB from 10 Hz to 1 kHz and > 40 dB to 15 kHz
Load reaction, capacitive load, etc.: see Appendix

Gain:

Input to mix output
Fader and pan in maximum position > + 12 dB
in calibrated position - 4.0 dB

Frequency Response:

Line input to master output
10 Hz to 40 kHz +/- 0.1 dB, 200 kHz - 4 dB (internal RF filters)

Phase Response:

Line input to master output
10 Hz <+ 6°, 20 Hz <+3°, 40 Hz <+1°, 10 kHz <-3°, 20 kHz <-10°

THD:

Line input to master output, 10 Hz to 20 kHz,
Level < +30 dBu: < 0.1 %,
Level + 20 dBu: < 0.03%

Crosstalk:

Channel to channel, 20 Hz to 20 kHz > 80 dB
Fader attenuation, 20 Hz to 4 kHz > 80 dB, 20 kHz > 70 dB
CUT switch attenuation, 20 Hz to 20 kHz > 80 dB

Signal to Noise Ratio:

all inputs loaded with 40 ohms, bandwidth 22 Hz - 22 kHz,
reference level 0 dBu = 0.775V
dBA values with A type weighting filter, dBu values unweighted, RMS

Mix Out L or R, all channels open,
all inputs CUT, -94 dBA / - 90 dBu
like above, faders and pan pots in calibrated positions, -80 dBA / - 75 dBu
PFL, -89 dBA / - 85 dBu

Dynamic Range:

all inputs loaded with 40 ohms, bandwidth 22 Hz - 22 kHz,
max. output level - noise voltage
dBA values with A type weighting filter, dBu values unweighted, RMS

Mix Out L or R, all channels open,
all inputs CUT, 124 dBA / 120 dBu
like above, faders and pan pots in calibrated positions, 110 dBA / 105 dBu
PFL, 119 dBA / 115 dBu

Current Consumption

see remarks in chapter, Power Supply Units,
quiescent Current < 500 mA, Power Consumption < 25 Watt
(With high output levels and low impedance load (600 Ohms) the current consumption increases by 35 mA per output.)

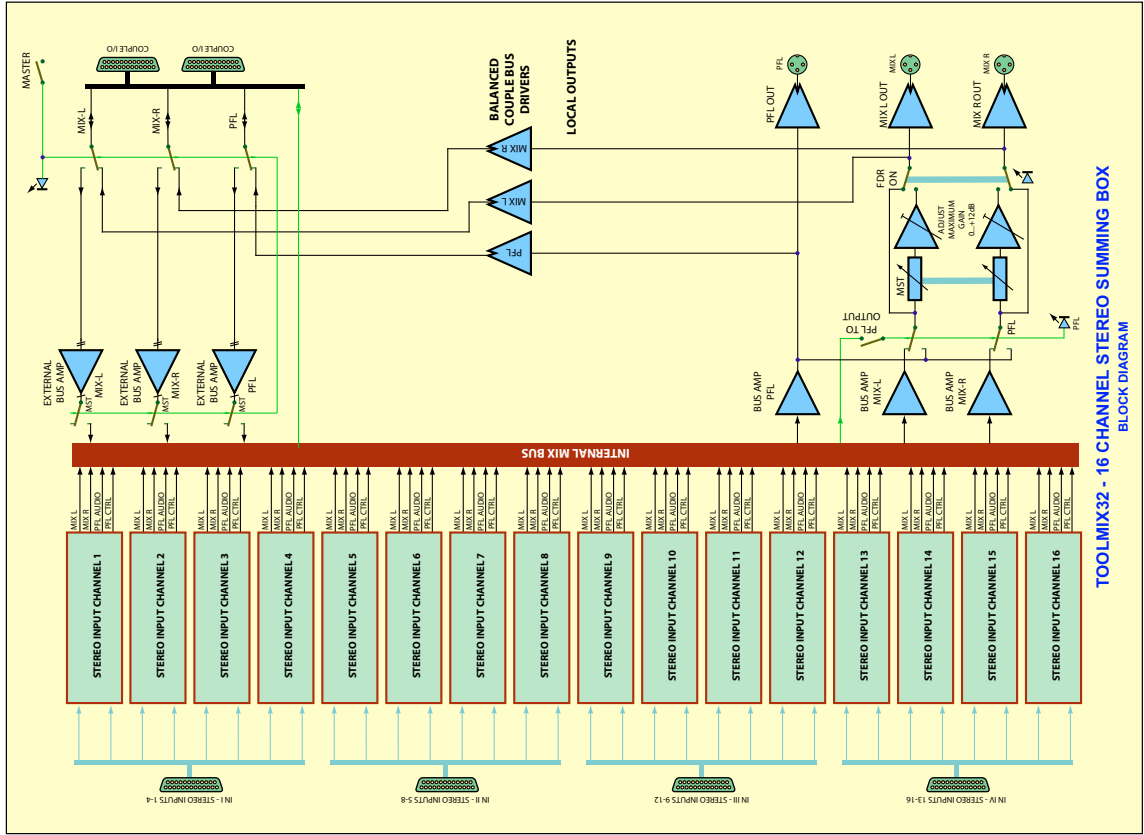

TOOLMIX32 - 16 CHANNEL STEREO SUMMING BOX
BLOCK DIAGRAM

ToolMst

Master module with Control Room Section and Playback/Talkback



The ToolMst adds all functions of a the master section of a conventional large format console to a ToolMix system. Of course, the unit can also be used stand alone, since the function set includes everything that is necessary for the handling of control room speakers and headphones and for any kind of recording sessions.

The device has five sections. Four **Stereo Inputs** can be used as effect returns, for the connection of additional mixers, or as normal stereo inputs. The **Master Section** has a rotary master fader, a balanced switched stereo insert and a stereo balance control. In addition to the stereo mix master there are master faders and output drivers for the two auxiliaries of the ToolMix8 devices. The **Control Room Section** contains a 10 position source selector, a complete control room regulator section which is capable to drive up to 4 different speaker systems and a headphone amplifier. The **Playback Section** makes possible to setup a playback mix from internal and external sources in a very easy way. A powerful headphone amplifier is included. In addition there is a separate output for studio speakers or external power amplifiers. Die **Talkback Section** includes a condenser microphone. In addition to external talkback outputs, talkback can be switched to the playback outputs. A versatile Remote Control section makes possible to integrate the ToolMst to external equipment.

The Stereo Inputs

The four Stereo Inputs are totally identical to the input channels of the ToolMix32 units. The inputs are electronically balanced and can handle levels of more than + 30 dBu. Fader, peak present indicator and PFL switch are driven directly from the outputs of the input amplifiers. The PFL circuits adds both the stereo inputs to a mono signal. The peak present indicator is a 3-color LED that displays levels of more than - 20 dB with green color. At 0 dB the color becomes yellow and changes via orange to red when the level increases. With red color there is still a headroom of 5 dB. The block diagram on the next page shows the circuitry of one of the four inputs.





Like with the ToolMix8, ToolMix 16 and ToolMix32, the faders of the input channels are rotary faders with calibrated center detent. Please refer to the manual of these units for details. The pan pots have a center attenuation of 0 dB. The precise calibration of the faders and the pan controls makes it possible to mirror a DAW mix to the analog mixer without the need of readjusting levels. However, it is alternatively possible to setup the mix manually as well. While using the inputs as effect return or sub group fader for additional, external mixers, the level and pan controls are essential. The huge maximum fader gain of 12 dB offers more than enough gain for all applications.

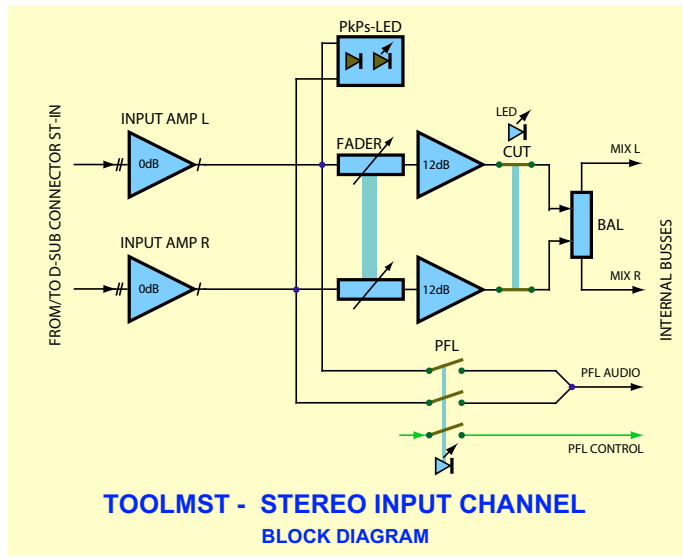

The Master Section

The Master Section of the ToolMst combines the stereo master, the two aux masters and the PFL master. In addition to the internal masters of the 4 stereo inputs, the couple port offers the choice to dock any number of ToolMix devices to the system.



The Stereo Master

The Stereo Master includes an electronically balanced, fully buffered, switched stereo insert that can be switched pre or post master fader. The insert inputs and outputs operate on nominal level. The output signal is always available on the connector panel while the insert input is switched into the master chain when the INSERT switch is pressed. Any external processing devices can be installed. The master fader is a precise rotary fader that allows making fade outs in an acceptable way. The maximum gain of the master fader can be internally adjusted and is normally calibrated to + 4 dB. In addition to the master fader, there is a stereo balance fader with 0 dB center attenuation that is inserted when the BAL switch is pressed. This fader allows fine adjustment of the left to right channel balance without the need to change the mix setting. The output of the stereo master is available on XLR connectors. The outputs are electronically balance and can handle levels of more than + 30 dBu. This output is internally connected to the MIX switches of the control room source selector and the playback

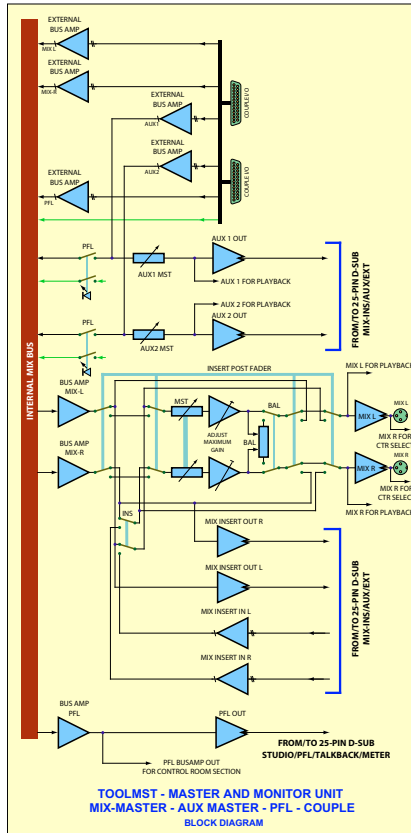

section. If the ToolMst is used with a ToolMox Console, internal jumpers make possible to disable reverse the couple port in a way that the internal mix, aux and PFL sections are disabled and the 4 stereo inputs can be coupled to the ToolMod Console.

Aux Masters

The two aux master sections are used as summing and output amplifiers for the auxiliaries one and two in the ToolMix8 devices. If no ToolMix units are included with a system, these masters don't have any function since they are not driven by an internal circuit. Each aux master section has a rotary master fader, a CUT switch and a PFL switch that routes the signal to the PFL summing bus. The auxiliary master section don't have their own control room select switches. Normally these outputs are control using

the PFL system. It is also possible to use of the 9 free stereo control room inputs for the aux master output by external wiring.

PFL

The PFL summing buss is part of the couple system. All PFL switches of a ToolMix/ToolMst system are mixed into this PFL bus. The control signal that is necessary for the automated switching functions of the PFL system are also coupled. The PFL output is electronically balanced. The unregulated output is available on one of the D-sub connectors. It can be used to install external meters or active speakers. In the ToolMst unit the PFL master can be switched automatically to either the control room speaker or the control room headphone output.

The Control Room Monitor Section

The Control Room Monitor Section combines all necessary functions for the source selection and regulation of the control room speakers and external meters.

Control Room Source Selector

A 10 position, mutual release switch block offers the choice to select the internal stereo master and 9 external stereo sources. The balanced inputs of this selector are available on 25-pin D-sub connectors. The switch block is electronically locked. Pressing more than one button at a time will not cause shortage of the sources. The stereo master in internally connected to the MST switch. The other 9 switches can be used in any desired way by external wiring to the 25-pin D-sub. The entire control room select section is balanced. The selector outputs available on the connector panel and can be used to drive external meters. The selector output feeds the input of the internal control room regulator section via a pair of buffer amplifiers.

Control Room Regulator Section



In addition to the volume pot there are a stereo balance control pot, a phase reversal switch, a switch to reverse the left and right channel and a mono matrix. The L-R reverses the left and right stereo channel. The phase switch reverses the phase in the right stereo channel. MNO inserts the mono matrix that adds both stereo channel with an attenuation of 6 dB per channel. 3 dB versions are available on request. The stereo balance control makes possible to shift the control speaker center position. In addition, it is possible to switch of the left and right channel to control one particular stereo channel when the pot is all to the right or all to the left. The center position of this pot is calibrated and leave the level unchanged. The control room dim of 15 dB with automatically activated with talkback. The dim function can also be remote controlled.

Control Room Headphone Amplifier

The additional headphone amplifier has its own volume control. The headphone is not affected by the dim system and the stereo balance control. The mono matrix, and the phase and left-right reversal affects both the speakers and the headphones. The output of the head-

phone amplifier is available on a TRS jack on the modules top plate. The amplifier can drive any kind of headphones.

PFL

Automatic switch over to PFL if one or more PFL switches are active in the entire system of coupled modules is possible. There are separate enable switches for the control room speakers and the control room headphones and a common volume control for the PFL level.

Control Room Speaker Outputs

Like all other outputs of the system, the control room speaker outputs are electronically balanced and able to handle levels of more than +30 dBu. Up to 4 different stereo speaker system can be installed. A 5 position, mutual release switch block selects one of the four speaker outputs. Switch number 5 mutes all speakers at a time. It is possible to switch on more than one speaker by pressing and locking several switches.

Playback Section



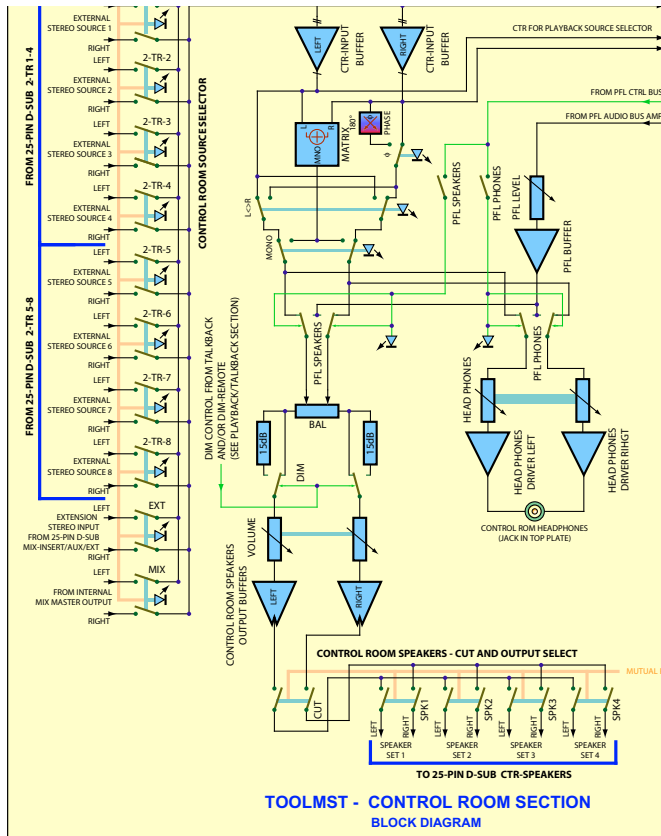

The Playback Section combines an adding source selector with a volume control, a talkback system and output drivers for studio headphones and for studio speakers. A 5 position mutual release switch block selects the playback source signal. 4 of the 5 switches are used to select the master outputs of Aux1, Aux2, the main stereo master MIX and the selected control room source signal CTR. Switch number 5, CUT, mutes the source selection but the talkback signal can still feed the studio headphones and speakers. Actually this source selector is a mixer. It is possible to lock more than one switch at a time to produce a fixed level mix of any number of sources. So it is possible to add one of the aux sends to the stereo master to use the signal on the stereo master as a basic playback mix while the tracks that need to have more level are added thru the auxiliary. It is self evident that the use of this function depends on the configuration of the entire system of coupled ToolMix devices. If there is no ToolMix8 in the system, there are no aux sends and you will be not able to use this principle. However, internal jumper setting makes it possible to reconfigure the ToolMst for the use with a ToolMix Console, which means that you can feed the AUX1, AUX2 and MIX switch of the playback source selector also externally. See the connector pinning of the ToolMst for details on that. The CTR switch is normally driven from the internal control room regulator system, pre all controls and switches, in stereo. Internal jumpers allow to use the EXT (Extension) input of the control room source selector instead. Using this option that requires to change the position of two internal jumpers lets you add another external stereo signal to the playback mix. Both the MIX and the CTR switch operate in stereo while the switches AUX1 und AUX2 operate in mono and feed both stereo channel in parallel.

The selected and mixed input signal drives the volume control fader PHONES via a mono matrix that can be inserted by the MONO switch



and the talkback insertion. The output of this fader feeds the two separate output driver stages for headphone and studio speakers. The headphone output is available on the top plate for direct control of the playback signal as well as on one of the 25-pin D-sub connectors.

The headphone amplifier can drive 3 to 4 headphones in parallel. All headphones should have the same impedance to avoid different levels. The jack on the top plate does not affect level or performance of the headphone that are connected on the rear panel D-sub connector. The additional balanced studio speakers output has independent driver amplifiers. It can be used for active studio speakers or power amplifiers for speakers and/or headphones as well. The speaker output can be muted by remote control.

Talkback

The Talkback system of the ToolMst combines a high quality electret type condenser microphone in the top plate, a low noise microphone preamplifier with gain control and the switching circuitry. A large format illuminated push button enables talkback. When the TB TO STU PHONES switch is pressed, talkback is routed to both the studio headphone and the studio speakers outputs. Actually the playback signal is attenuated by 20 dB while the talkback signal is mixed to the playback signal.

The remote port allows the installation of external talkback switches. In addition there is a control output that is low when talkback is active. The talkback signal is available on one of the 25-pin D-sub connectors. The output driver is electronically balanced and operates at

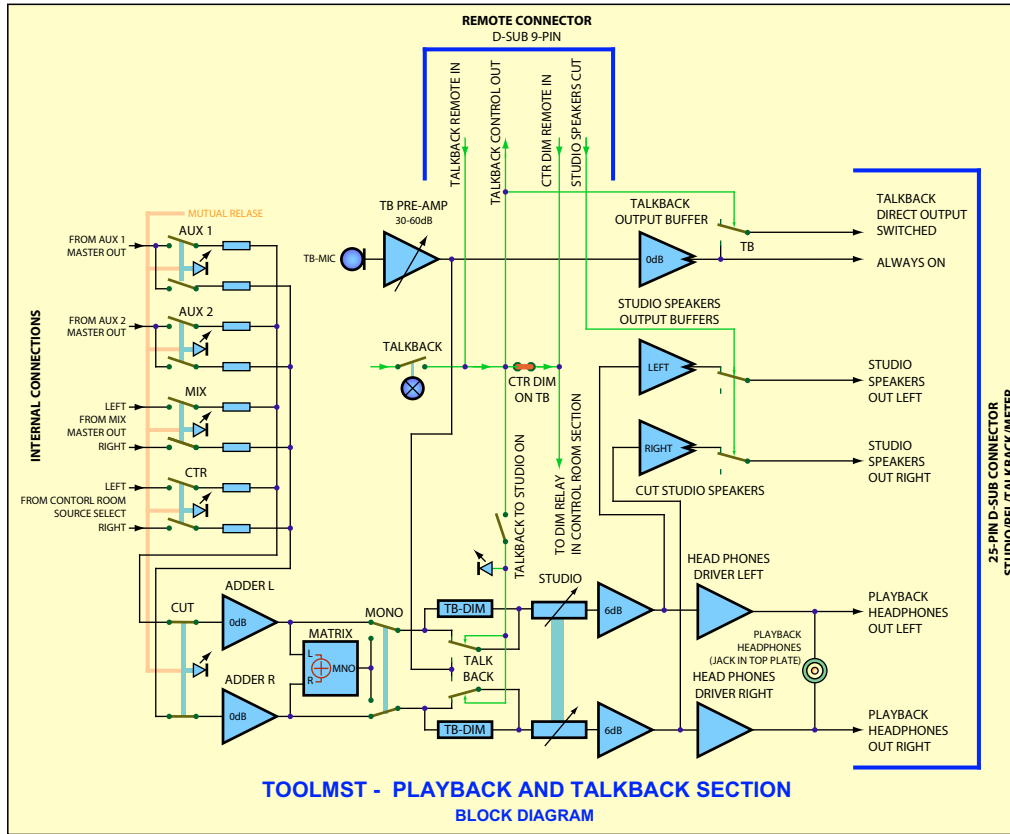

line level. Output 1 is always on while output 2 is switched with the talkback switch and/or remote control.

The block diagram on the left side shows the playback/talkback section in detail while the diagram on the next page shows the internal wiring of the ToolMst unit.

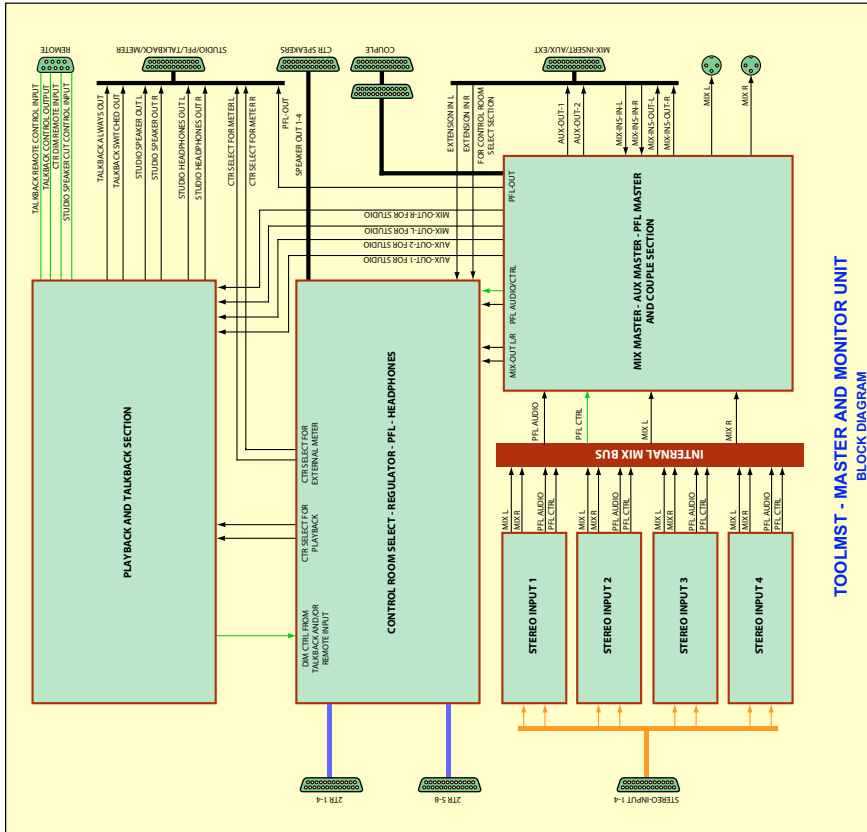

TOOLMST - MASTER AND MONITOR UNIT
BLOCK DIAGRAM

Technical Data ToolMst

Inputs:

Summing inputs: 4 x stereo
 Control room source select inputs: 9 x stereo
 Stereo master: 2 x insert in electronically balanced, nominal level + 6 dBu
 maximum input level > + 30 dBu,
 input impedance > 10 kOhm,
 CMRR according to IRT > 75 dB from 10 Hz to 1 kHz
 and > 65 dB bis 15 kHz

Outputs:

5 master outputs for MIX L, MIX R, AUX1, AUX2 and PFL
 4 stereo control room speaker outputs, SPK1 to SPK4
 1 stereo studio speaker output
 2 talkback outputs
 electronically balanced, nominal level + 6 dBu
 maximum output Level > + 30 dBu,
 source Resistance < 50 Ohm
 CMRR according to IEC, > 50 dB from 10 Hz to 1 kHz
 and > 40 dB to 15 kHz
 Load reaction, capacitive load, etc.: see Appendix

2 stereo headphone outputs, for control room and studio, unbalanced, for headphones of any impedance
 maximum output power 0.3 Watt
 maximum output level, open circuit + 24 dBu
 Source resistance 50 Ohm

Gain:

Inputs in calibrated center position
 to stereo master outputs,
 master fader calibrated,
 all pan pots in center position -4.0 dB
 maximum gain, input and master fader open > + 16 dB



Frequency Response:

Line input to master output, control room section, studio section
10 Hz to 40 kHz +/- 0.1 dB, 200 kHz - 4 dB (by internal RF filters)

Phase Response:

Line input to master output, control room section, studio section
10 Hz <+ 6°, 20 Hz <+3°, 40 Hz <+1°, 10 kHz <-3°, 20 kHz <-10°

THD:

Line input to master output, control room section, studio section
10 Hz to 20 kHz,
Level < +30 dBu: < 0.1 %,
Level + 20 dBu: < 0.03%

Crosstalk:

(worst case values)
Input channel to input channel, 20 Hz to 20 kHz > 80 dB
Fader attenuation, 20 Hz to 4 kHz > 80 dB, 20 kHz > 70 dB
CUT switch attenuation, 20 Hz to 20 kHz > 80 dB
Control room select inputs, source resistance 40 ohms, 20 Hz to 20 kHz >80 dB
Stereo crosstalk, left - right, master, control room section, studio section,
20 Hz to 20 kHz > 60 dB

S/N:

Inputs loaded with 40 ohms, bandwidth 22 Hz - 22 kHz,
reference level 0 dBu = 0.775V
dBa values with A type weighting filter, dBu values, unweighted, RMS
Mix out L or R, all 4 channels open, fader and pan in calibrated position
-95 dBa / - 91 dBu
as above, but all inputs CUT
-96 dBa / - 92 dBu
Aux out 1 or 2, PFL
-95 dBa / -91 dBu
Control room outputs, studio speaker outputs, no input selected,
Fader open, all other functions off
-95 dBa / -91 dBu

Signal to Noise of coupled ToolMix systems are the result of the geometric addition of the noise voltages of the coupled devices. This means that twice the number of input channels increases the noise level by 3 dB. The noise of a system with 64 channel is 3 dB higher than the noise of a system with 32 channels.

Dynamic Range:

Inputs loaded with 40 ohms, bandwidth 22 Hz - 22 kHz,
max. output level - noise level
dBa values with A type weighting filter, dBu values, unweighted, RMS

Mix Out L or R, all channels open, gain and faders in calibrated positions
125 dBa / 121 dBu
like above but all inputs CUT
126 dBa / 122 dBu
PFL
125 dBa / 121 dBu
Control room outputs, studio speaker outputs, no input selected,
Faders open, all other functions off
125 dBa / 121 dBu

Current Consumption

see remarks in chapter, Power Supply Units,
quiescent current < 500 mA, Power Consumption < 25 Watt
(With high output levels and low impedance load (600 Ohms) the current consumption increases by 35 mA per output.)



Appendix

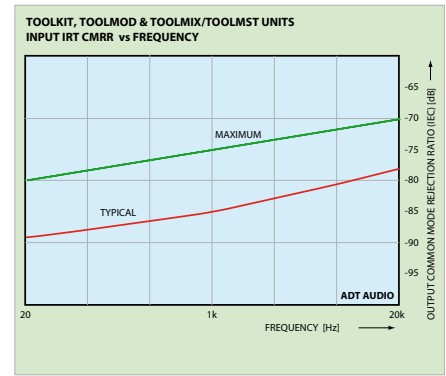
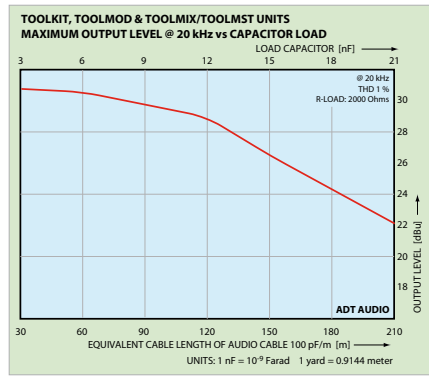
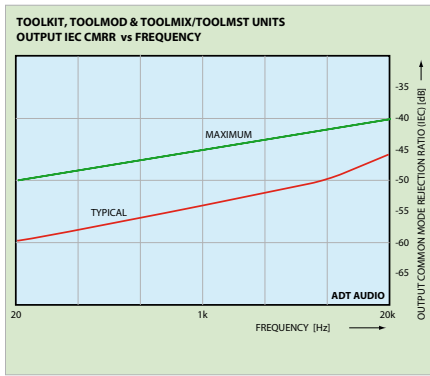
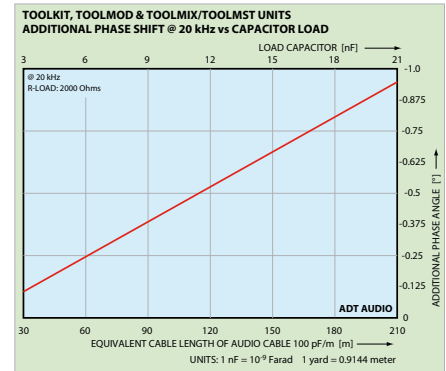
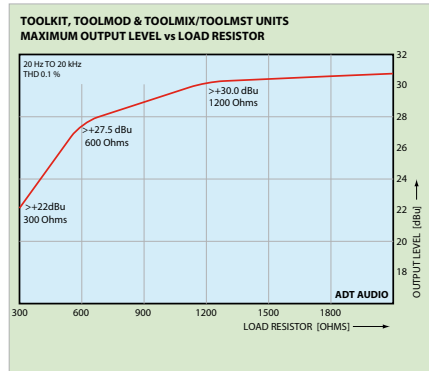
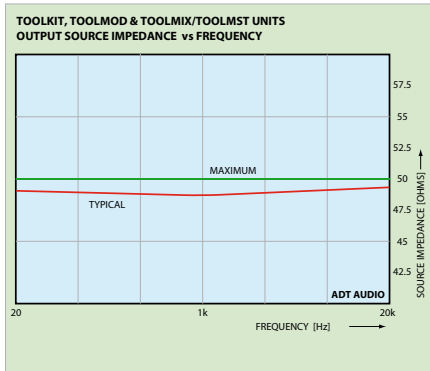



Power Supply

ToolKit, ToolMix, and ToolMod use the same power supply units. The selection of an appropriate power supply unit for a particular Tool system depends on the current consumption of the units. Three power supply units with different output current capacity are available. All power supply units have the same output voltages and use the same 5-pin xlr connectors. Of course, larger systems with many Tool units can be supplied with several power supply units as well. All power supply units have 3 output voltages; a balanced, +/- 25 V audio supply and an additional + 48 V phantom supply that is used for the mic preamplifiers only.

ToolPwr-M

ToolPwr-M is the small power supply unit with 80 VA output power. The maximum output current of the audio supply is 1 ampere and the peak output current is 1.5 ampere. The capacity of the phantom power is sufficient for up to 15 mic preamps. This unit can be used for 2 to 3 Tool units or 1U high ToolMod frames. It is best suited for small systems or single units and for its low price the best choice for such small systems. The housing is a small, stable desktop housing. The dimensions are 120 mm x 60 mm x 275 mm. Brackets can be installed instead of the rubber feet that make possible to mount the unit to the side panel or rear panel of a rack. Alternatively, a 2U high 19" top plate and a fixing bracket are available for rack-mounting.



ToolPwr-S

This is the standard power supply unit of the Tool system. The power capacity of 2 amperes constant and 3 amperes peak makes possible to use this unit with 4 to 6 Tool units or 1U high ToolMod frames. ToolPwr-S is a 2U high rack-mounted unit with a depth of 210 mm, without connectors. It comes with 2 output connectors in parallel.



ToolPwr-E

ToolPwr-E is the high capacity version of the Tool power supply units. It uses the same housing as the ToolPwr-S, but it has a larger heat sink, a larger power transformer, high-current voltage regulators, and doubled filter capacitors. The constant output current is 4 amperes and the peak output current is 6 amperes. The unit can handle a minimum of 8 units under worst-case conditions. Up to 12 Tool units are possible, depending on the particular current consumption of the devices. Like the ToolPwr-S, it is a 2U high rack-mounted device, 210 mm deep, with 2 output connectors in parallel.





Current Consumption

Even though the current consumption of the different Tool units is different, you may use a value between 400 and 500 mA per 1U high device for a rough estimation of the total supply current. This rule of thumb is valid for the entire Tool series and the 1U high ToolMod frames with almost all possible combinations. The current of 400 – 500 mA is the quiescent current that under almost all circumstances is identical to the operating current. However, the actual the current consumptions depends on the load resistance of the outputs and the level. It is obvious, that low values of the load resistor increase the output current and therefore the output power. This is Ohm's law and not a special characteristic of the Tool devices. Since the maxi-

mum output voltage is + 30 dB and the maximum output power of each output is approximately 1 Watt, each heavy loaded output will increase the current consumption of the device, as soon as the output level gets high.

In real world situations, this does not really matter. Almost all audio devices have and had an input impedance in the range of 5 kOhms to 20 kOhm. The current with high output levels with a load of 5 kOhms or more can be neglected, since there will be no relevant increase of the total supply current. One or two ancient 'vintage' devices with 600 ohms input impedance will also not change the total current of a Tool system dramatically.

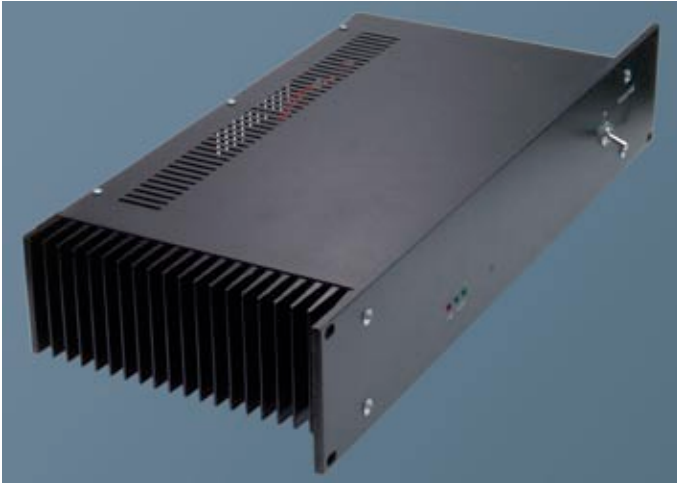

ToolPwr-E side view



ToolPwr-S side view



However, if you have a large number of low input impedance gear and if you use it on the outputs of a pile of Tool units, a significant increase of the necessary current is likely. Please consider using a larger power supply unit. Figure that each output with full load of 1 watt requires additional 30 mA of supply current.

Mains Power

The power supply units of the Tool system are designed for a nominal mains voltage of 230 V / 50 Hz or 115 V / 60 Hz. All units for export to countries outside the European Union come with a voltage selector for 230 and 115V. The different frequencies of 50 or 60 Hz are not important for the performance of the power supply units.

The technical properties of the Tool units are observed with a supply voltage of +/- 25V, +/- 1 Volt. The power supply units deliver these output voltages, unless the mains voltage is lower than 215 V or 107 V respectively. A lower mains voltage will cause the internal regulators to drop out. This causes a 100 Hz / 120 Hz saw tooth hum that is superposed to the DC output voltage. This hum will appear on the audio outputs of the devices. The reserve to a drop of the mains voltage is larger, if the load of the particular power supply section is low. If you have such a problem, please measure the mains voltage and get in touch with us. Humming can have a pile of different reasons and in most cases, the power supply will not be the reason but a ground loop.

If the mains voltage is very high, nothing will happen at all. However, the voltage regulators of the power supply unit regulate the high voltage down to +/- 25 V. The total power dissipation of the power unit is a lot higher and the temperature of heat sink increases. If this causes trouble depends only on the ventilation of fresh air along the heat sink of the power supply. If the airflow is sufficient to transport

heat away from the power supply everything is okay. If airflow and power dissipation is out of balance, the power supply will heat up increasingly until the internal thermal protection circuit shuts down the current to prevent severe damage. With this mode, the output voltage is very low and very dirty. The audio signal is distorted and superposed with interfering noise. If this happens, switch off and let the power supply cool down for a while. As soon as the temperature is down, the unit will work properly. If this is the case on a very hot summer day or when your air condition was off, do not care. If it becomes a constant problem, check the mains voltages and check how the power supply is installed. The easiest way to get rid of such problems is always to take care for appropriate ventilation of the power supply that of course cannot have a fan installed – you would not like to have such a unit in your control room. Make sure that airflow is possible from the bottom of the unit to the top along the heat sink and thru the ventilation holes in the bottom and top sheets of the housing. The easiest way is to install a 1U high blind panel with ventilation holes below and above the power supply unit.





Standard Power Cables

Cables for the connection of the power supply are available in 2 standard versions. The 10 ft. version is used for the connection from the power supply to the first device in a block of several units or for a single unit.

The 1 ft. version is used to daisy chain the power supply from unit to units. Cables with different lengths are possible on special order at short notice.

These cables can also be used with the ToolMix/ToolMst units and the ToolMod system.



Maintenance

Die Tool devices do not require regular maintenance. In case of trouble get in touch with us:

E-Mail: support@adt-audio.com Phone 0049 2043 5061

Environment

The environmental conditions have great influence on the long-term stability and reliability of the entire device.

Temperature

The recommended operating temperature range is from 10 °C to 45 °C. The devices will also operate at temperatures above and below this limit of course. However, operating at temperatures outside this range for long periods can reduce the lifespan.

Continuous Operation

Under normal conditions, we recommend that you power down the devices if they are not in use. The units are ready for use within a minute. They will reach a steady operating temperature within the first hour of operation. There is no reason to leave the system switched on constantly.

Within the first weeks of operation, the devices should not run in continuous operation. Failure of an IC, an electrolytic or other early failure is most likely in the first weeks of operation.

Soiling

The entire device should be kept as dust and dirt free as possible. If drinks or other liquids are accidentally spilled onto the devices, the units must be immediately removed and a cleaned. We recommend



the use of Isopropyl alcohol for cleaning. Isopropyl alcohol will not damage the components of the devices. The sooner the remains of any spilled liquid is cleaned, is the less risk there is of damage.

Cleaning

Only non-corrosive cleaners such as Isopropyl alcohol should be used for cleaning. Isopropyl alcohol is the best choice for all parts, including the plastic knobs and caps and the pushbutton knobs, all electric components and the top plates. Cleaners that are more aggressive can cause problems because they might corrode mechanical or electrical components. **Do not use any kind of thinner** – you will have to replace all plastic parts that were exposed to the thinner.

If you use Isopropyl alcohol MAKE SURE THAT THE ALCOHOL IS EVAPORATED BEFORE YOU RECONNECT THE POWER to avoid the RISK OF FIRE, DAMAGE AND ELECTRIC SHOCK!

Lifespan

Though no regular maintenance is necessary, you can reduce wear and tear and extend the lifespan by following some simple rules: Avoid smoking, dust, dirt, and moisture and use all controls on a regular basis. The electro mechanical components, like switches, pots, faders, relays, etc., are more or less sensitive to dust, moisture, smoke, and dirt. When used regularly, the self-cleaning properties of these components work well and keep the component free from soil. Actually, there are many controls in a complex audio system that are not used for weeks or even months. The best you can do to extend the lifespan and keep your gear working without problems is easy to accomplish:

Turn every pot about 5 times from all to the left to all to the right and back to the left. Use all switches and press each pushbutton about 5 to 10 times.

Repeat this procedure every 3 month.

With this little effort you will avoid noisy pots and switches and most of the problems that may come up after 10 to 15 years of use.



Limited Warranty

adt-audio® manufactures its products to very high standards and we are confident our products will perform well. Accordingly, we provide a limited warranty term of two years. For countries where minimum warranty terms are determined by statute, the warranty term is the statutory period required.

The limited warranty covers the functionality of the product for its normal, intended use as specified in the product description and the manuals. It does not cover a malfunction or damage that has resulted from improper or unreasonable use or installation, using faulty ancillary equipment, modifications, unauthorized repair, shipping damage or loss, abuse, accidents, use of improper voltage/current, power surges, lightning or other acts of God, excess moisture, normal wear and tear, or purchase from unauthorized dealers. Proof of purchase directly from the factory or from an authorized dealer may be required for warranty services. If you have purchased the equipment from a dealer, contact the dealer for warranty service or repair.

Please refrain from opening this product or taking it apart as doing so will void this Limited Warranty. Installing or removing ToolMod® modules to or from ToolMod frames in the way it is described in this manual will not affect the Limited Warranty. However, we will not pay for costs incurred due to correction of installation problems, elimination of externally generated noise, loss of time, inconvenience, loss of use of product, or damage caused to improper use of this product. In the event the product is returned during warranty term and is legible for service under this Limited Warranty, we will repair or replace any defective parts within a reasonable period and free of charge for work and parts.

This Limited Warranty gives you specific legal rights subject to specified conditions. You may also have other legal rights, which apply to the product you have acquired. These legal rights vary from country to country. Some places do not allow the exclusion, restriction, or modification of certain implied rights or their effect. In those situations this Limited Warranty will only apply to the extent that the applicable law allows.

The laws in your country may provide you with legal claims against the seller or manufacturer of this product. This Limited Warranty does not affect those rights. The provisions of the Limited Warranty are in lieu of any other warranties or conditions, except those provided by law and do not preclude any remedy you have under law.

In countries where liability limits are not precluded by statute, the maximum liability of the dealer or manufacturer shall not exceed the purchase price of paid by you for the product. In countries where limitations of liability are precluded by law, the dealer or manufacturer shall be liable for no more than the direct damages for bodily injury, and/or real or personal property arising from the negligence of the dealer or manufacturer.

Where not prohibited by law, dealer or manufacturer shall not be liable for special, incidental, consequential or indirect damages. Some places do not allow limitations in the exclusion of limitation of relief, special, incidental, consequential or indirect damages, or the limitation of liability to specified amounts, so the above limitations or exclusion may not apply to you.

This Limited Warranty is void if the serial number has been removed or defaced.

